

MORIWAKI MD250H PARTS LIST

VIN. No. MD250HUS-0900023

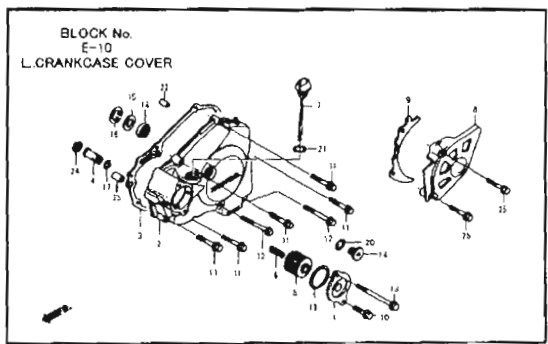

BLOCK No.
E-11
GENERATOR

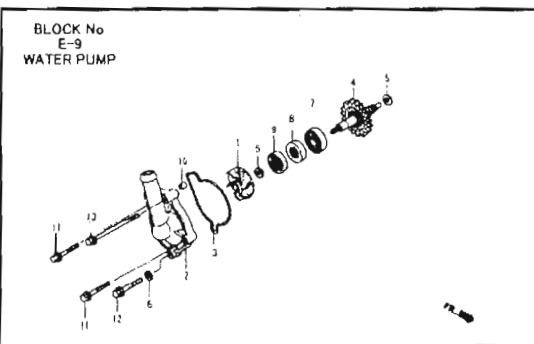
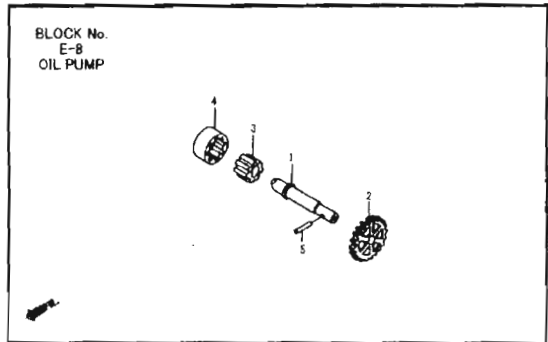
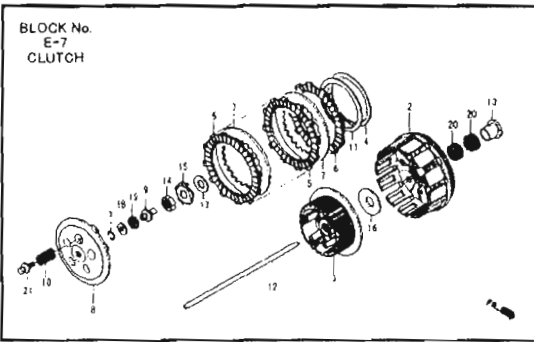
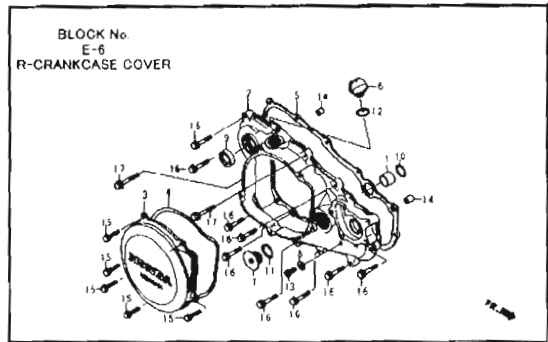
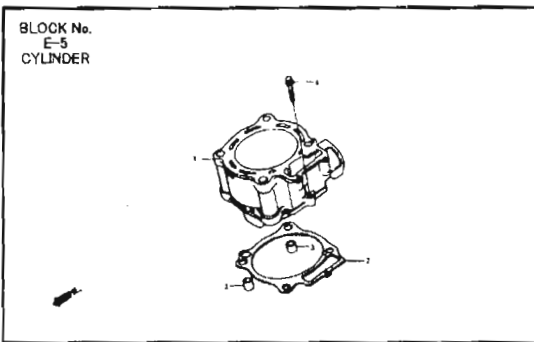
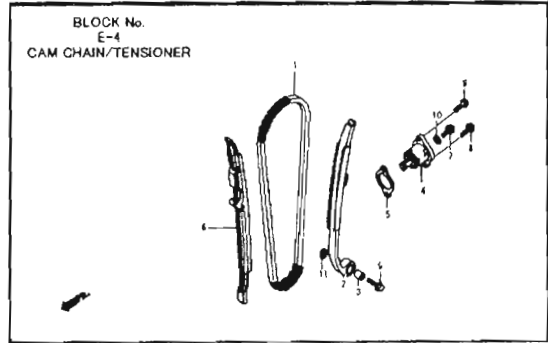
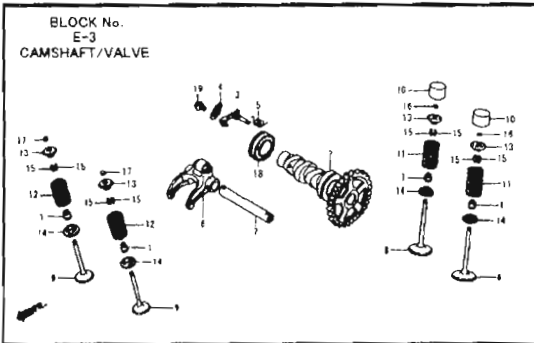
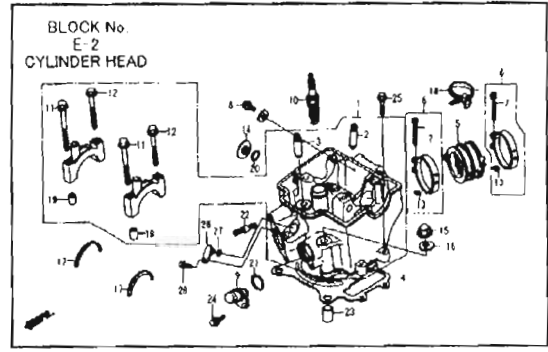
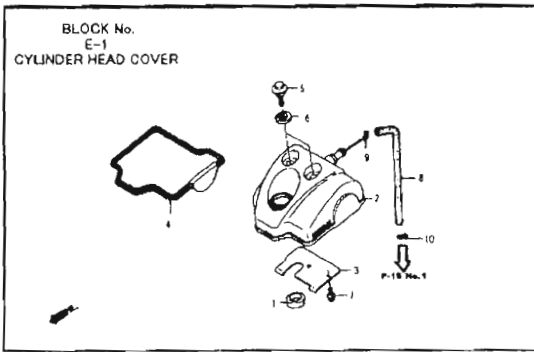
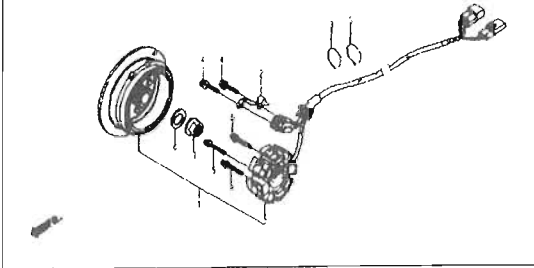

BLOCK No.
E-12
STARTING MOTOR

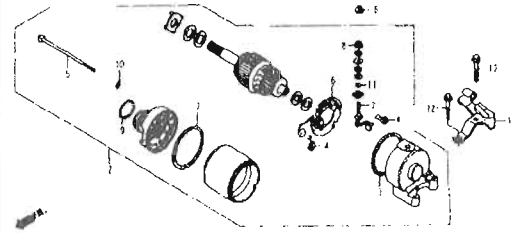

BLOCK No.
E-13
STARTING CLUTCH

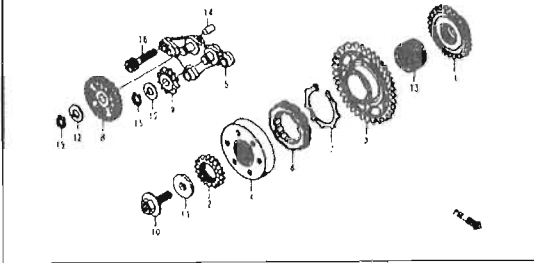

BLOCK No.
E-14
CRANKCASE

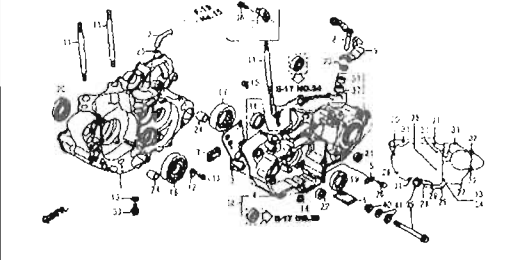

BLOCK No.
E-15
CRANKSHAFT/PISTON

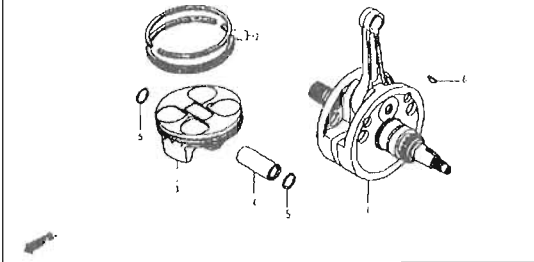

BLOCK No.
E-16
BALANCER

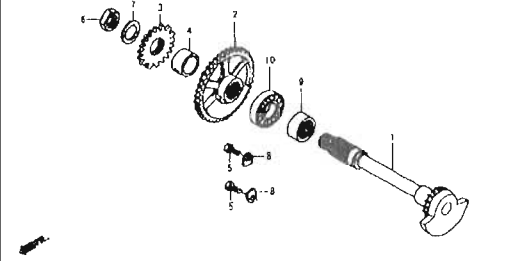

BLOCK No.
E-17
TRANSMISSION

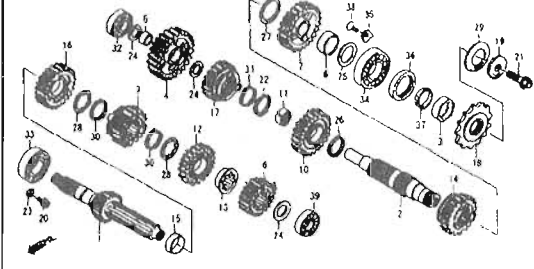

BLOCK No.
E-18
GEARSHIFT DRUM

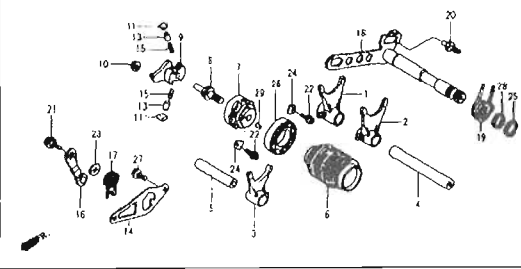

BLOCK No.
E-19
KICK STARTER SPINDLE

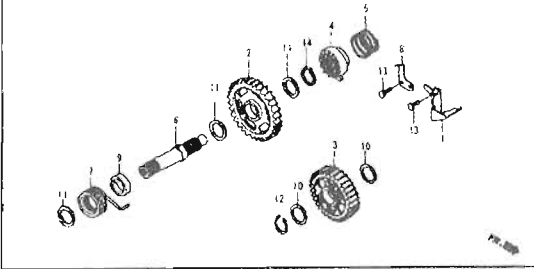

BLOCK No.
E-20
CARBURETOR

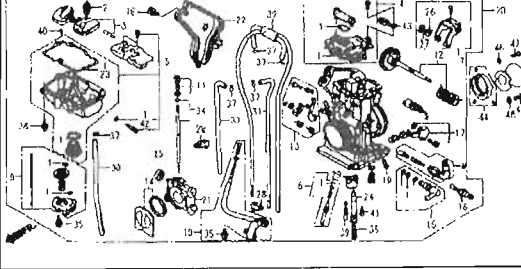

BLOCK No.
E-20-1
CARBURETOR, O.P. KIT

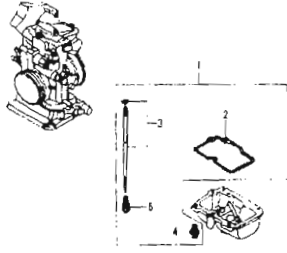

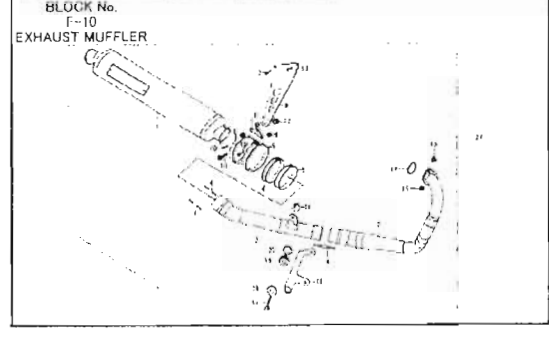
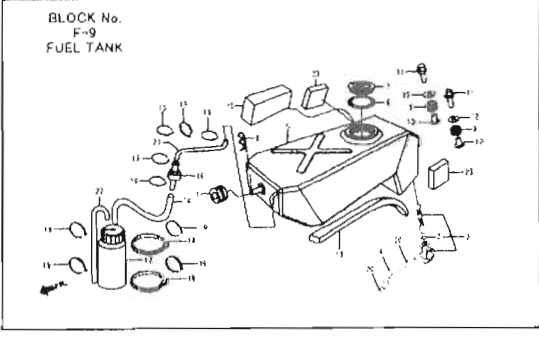
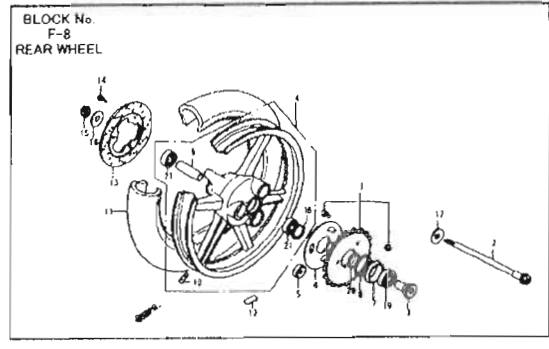
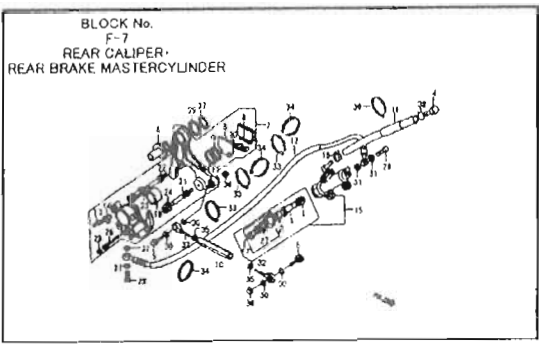
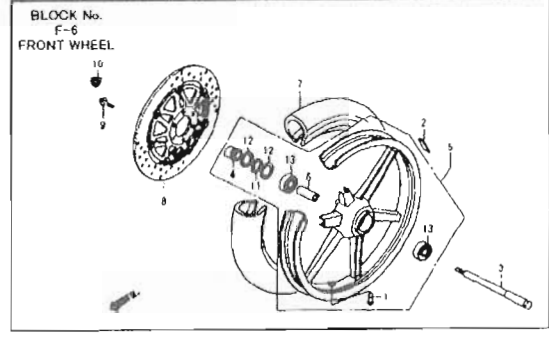
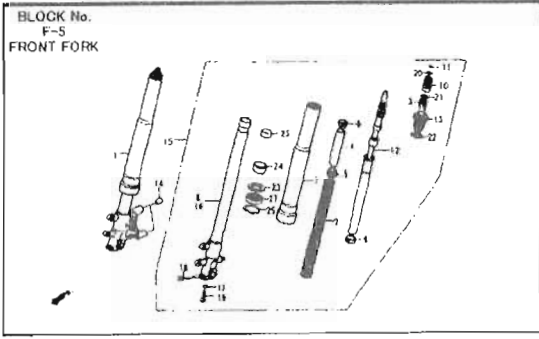
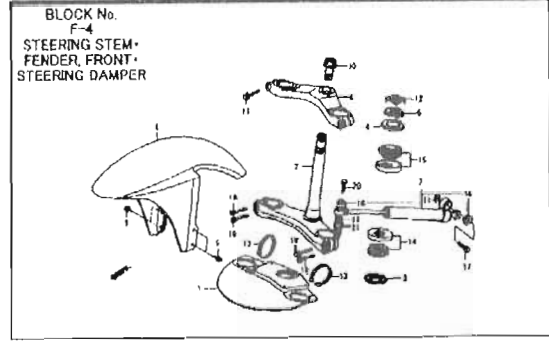
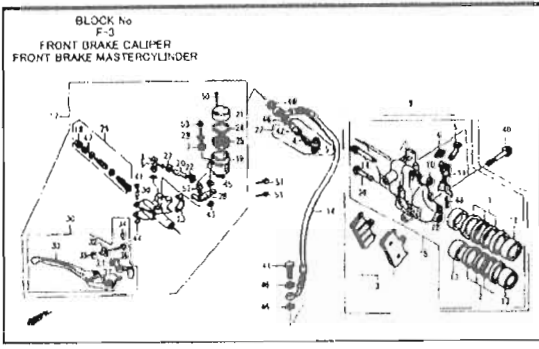
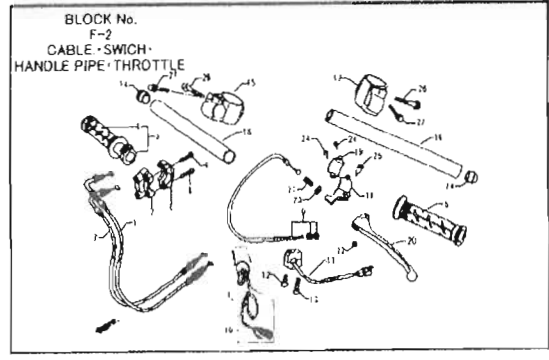
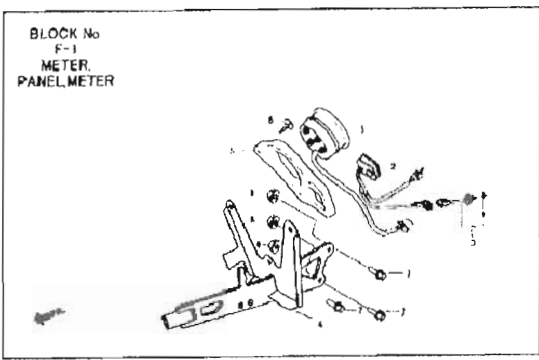

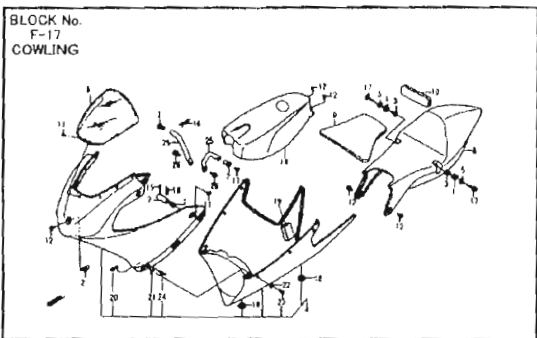
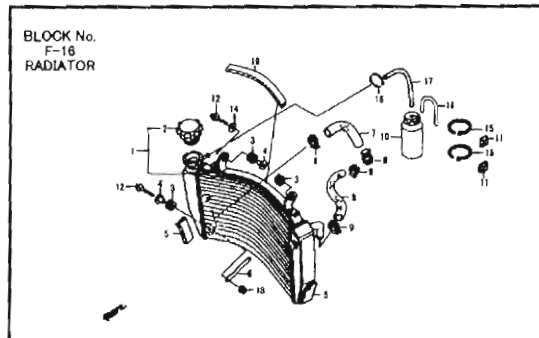
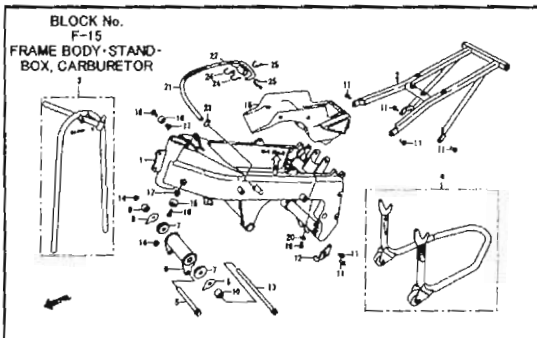
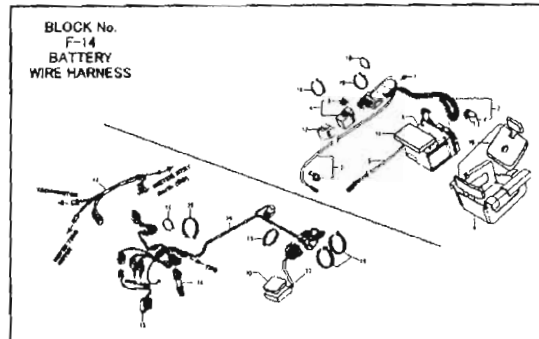
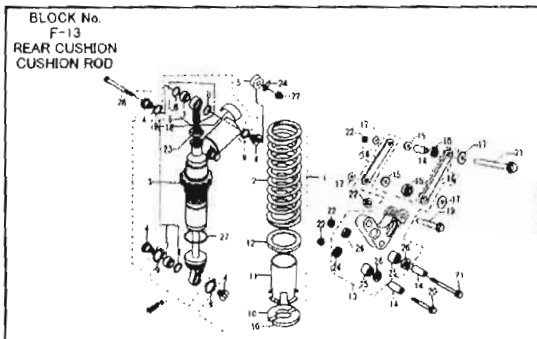
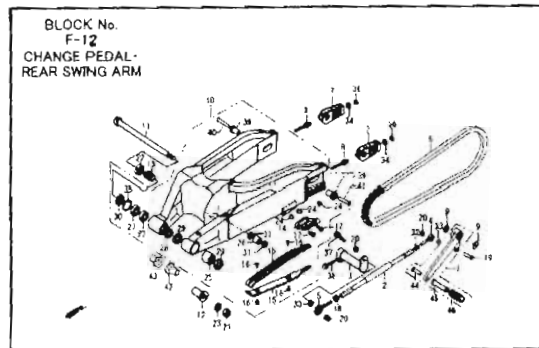
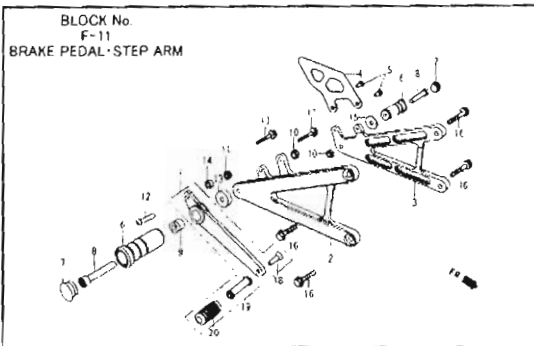

BLOCK No.
E-1
CYLINDER HEAD COVER

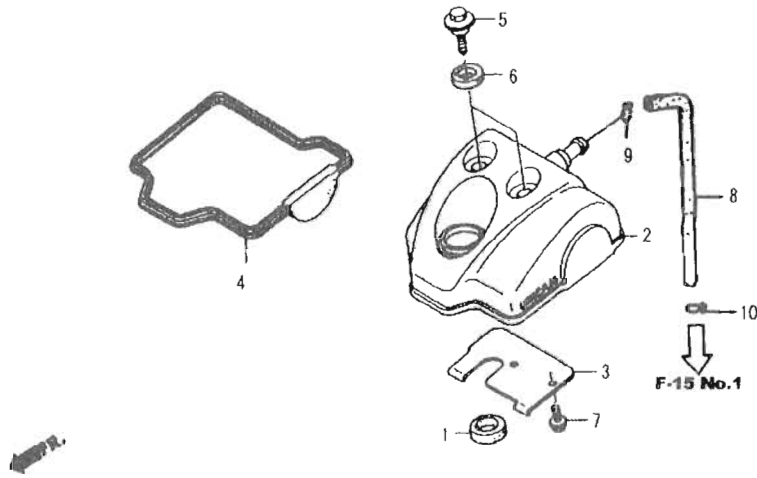

Ref. No.	Part No.	Description	Reqd. QTY	Retail Price
1	12226-MEB-670	SEAL,RING	1	
2	12310-KSC-A30	COVER COMP.,CYLINDER HEAD	1	
3	12316-KRN-670	PLATE,BREATHER	1	
4	12391-KRN-670	GASKET,HEAD COVER	1	
5	90017-MY9-790	BOLT,HEAD COVER	2	
6	90543-MV9-670	RUBBER,MOUNTING	2	
7	96300-06012-00	BOLT,FLANGE, 6x12	2	
8	17372-KRN-000	TUBE A,BREATHER	1	
9	15771-551-000	CLIP,OIL DRAIN TUBE	1	
10	95002-02120	CLIP,TUBE (B12)	1	

BLOCK No.
E-2
CYLINDER HEAD

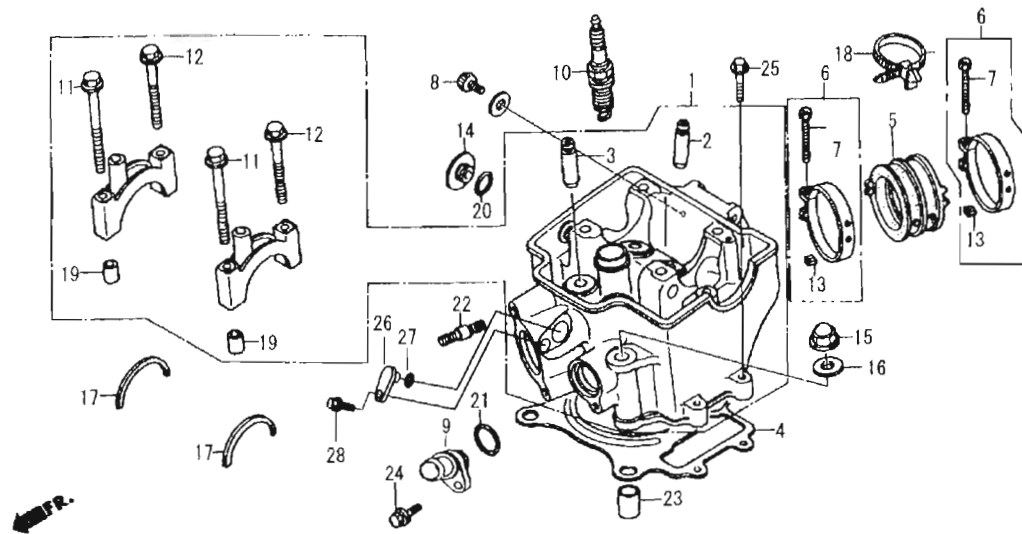

Ref. No.	Part No.	Description	Reqd. QTY	Retail Price
1	12010-KSC-D10	HEAD ASSY., CYLINDER	1	
2	12204-KRN-P00	GUIDE, IN. VALVE (OS)	2	
3	12205-KRN-P00	GUIDE, EX. VALVE (OS)	2	
4	12251-KRN-731	GASKET, CYLINDER HEAD	1	
M 5	16211-10512-85	INSULATOR, CABURETOR	1	
6	16218-MCJ-000	BAND B, INSULATOR	2	
7	16222-MV4-300	NUT, SQUARE, 5MM	2	
M 8	970000-05006	BOLT, CAP 5x6	1	
M 9	19523-10512-00	PIPE, WATER	1	
10	31910-NL3-871	SPARK PLUG (R0409B-10)	1	
11	90001-KRN-670	BOLT, FLANGE, 7x60	2	
12	90002-KRN-670	BOLT, FLANGE, 7x50	2	
13	90005-MCJ-000	BOLT, RECESSED, 5x28	2	
14	90084-MEN-670	CAP, 14MM	1	
15	90232-MB6-680	NUT, CAP, 9MM	4	
16	90401-KRN-670	WASHER, PLAIN, 9MM	4	
17	90446-KRN-670	WASHER, CAMSHAFT THRUST	2	
18	90672-SA0-003	STRAP, CABLE, 118MM(BLACK)	1	
19	90701-MR7-000	DOWEL PIN, 9x14	2	
20	91303-377-000	O-RING, 13.8x2.5	1	
21	91312-KE7-003	O-RING, 19x3 (NOK)	1	
22	92900-08022-0B	BOLT, STUD, 8x22	2	
23	94301-12200	DOWEL PIN, 12x20	2	
24	96001-06020-00	BOLT, FLANGE, 6x20	1	
25	96001-06028-00	BOLT, FLANGE, 6x28	2	
M 26	18640-10512-771	CAP, PLUG	1	
27	91305-PE2-003	O-RING, 9.8X1.9	1	
28	96001-06016-00	BOLT, FLANGE, 6X16	1	

BLOCK No.
E-3
CAMSHAFT/VALVE

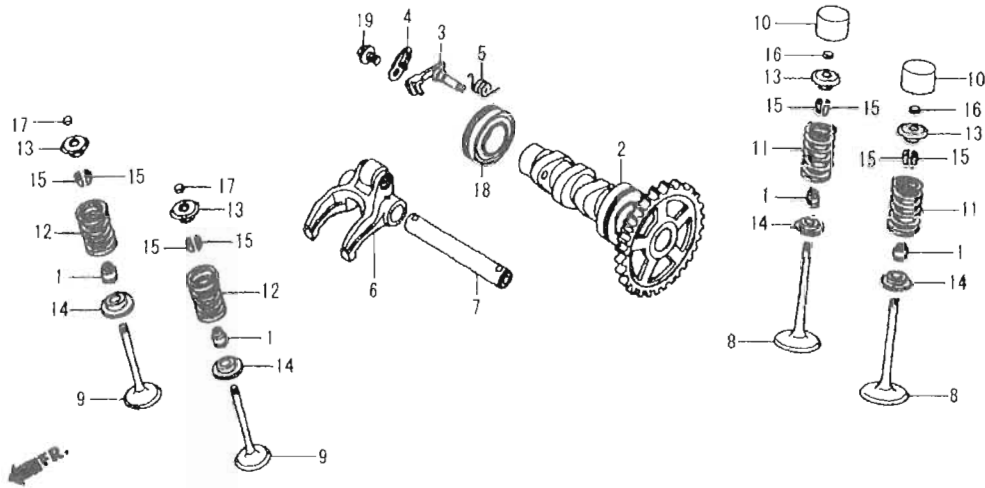

Ref. No.	Part No.	Description	Reqd. QTY	Retail Price
1	12209-GB4-681	SEAL,VALVE STEM (NOK)	4	
2	14100-KSC-670	CAMSHAFT COMP.	1	
3	14102-KRN-670	WEIGHT,DECOMPRESSION	1	
4	14105-KRN-670	PLATE,WEIGHT SETTING	1	
5	14106-KRN-A00	SPRING,DECOMPRESSION	1	
6	14440-KRN-670	ARM COMP.,EX.ROCKER	1	
7	14451-KSC-671	SHAFT,EX.ROCKER ARM	1	
8	14711-KRN-670	VALVE,IN.	2	
9	14721-KRN-670	VAVE,EX.	2	
10	14731-KRN-A00	LIFTER,VALVE	2	
11	14751-KRN-670	SPRING,IN.VALVE	2	
12	14761-KRN-671	SPRING,EX.VALVE	2	
13	14771-KRN-A00	RETAINER,VALVE SPRING	4	
14	14775-KRN-670	SEAT,VALVE SPRING	4	
15	14781-MAT-000	COTTER,VALVE	8	
16	14901-KT7-013	SHIM,TAPPET (1.200)	2	
	14902-KT7-013	SHIM,TAPPET (1.225)	2	
	14903-KT7-013	SHIM,TAPPET (1.250)	2	
	14904-KT7-013	SHIM,TAPPET (1.275)	2	
	14905-KT7-013	SHIM,TAPPET (1.300)	2	
	14906-KT7-013	SHIM,TAPPET (1.325)	2	
	14907-KT7-013	SHIM,TAPPET (1.350)	2	
	14908-KT7-013	SHIM,TAPPET (1.375)	2	
	14909-KT7-013	SHIM,TAPPET (1.400)	2	
	14910-KT7-013	SHIM,TAPPET (1.425)	2	
	14911-KT7-013	SHIM,TAPPET (1.450)	2	
	14912-KT7-013	SHIM,TAPPET (1.475)	2	
	14913-KT7-013	SHIM,TAPPET (1.500)	2	
	14914-KT7-013	SHIM,TAPPET (1.525)	2	

BLOCK No.
E-3
CAMSHAFT/VALVE

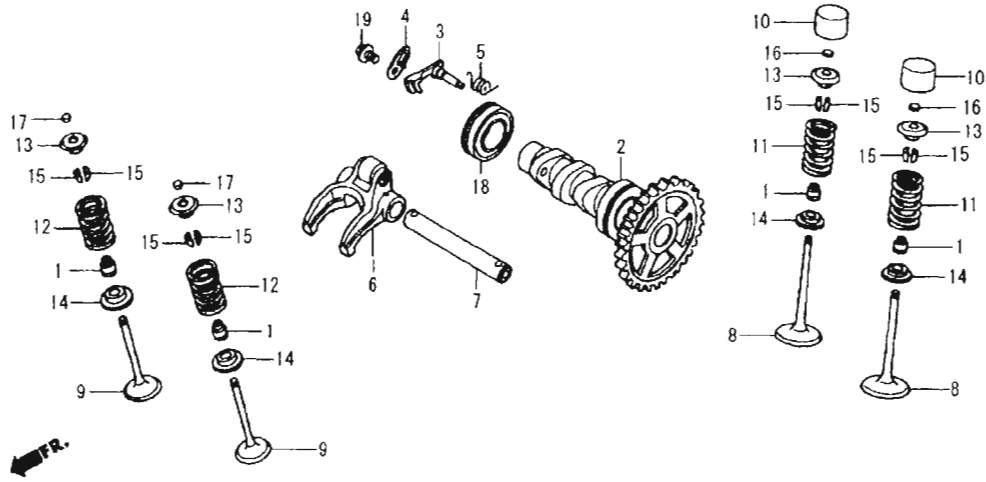

Ref. No.	Part No.	Description	Reqd. QTY	Retail Price
(16)	14915-KT7-013	SHIM,TAPPET (1.550)	2	
	14916-KT7-013	SHIM,TAPPET (1.575)	2	
	14917-KT7-013	SHIM,TAPPET (1.600)	2	
	14918-KT7-013	SHIM,TAPPET (1.625)	2	
	14919-KT7-013	SHIM,TAPPET (1.650)	2	
	14920-KT7-013	SHIM,TAPPET (1.675)	2	
	14921-KT7-013	SHIM,TAPPET (1.700)	2	
	14922-KT7-013	SHIM,TAPPET (1.725)	2	
	14923-KT7-013	SHIM,TAPPET (1.750)	2	
	14924-KT7-013	SHIM,TAPPET (1.775)	2	
	14925-KT7-013	SHIM,TAPPET (1.800)	2	
	14926-KT7-013	SHIM,TAPPET (1.825)	2	
	14927-KT7-013	SHIM,TAPPET (1.850)	2	
	14928-KT7-013	SHIM,TAPPET (1.875)	2	
	14929-KT7-013	SHIM,TAPPET (1.900)	2	
	14930-KT7-013	SHIM,TAPPET (1.925)	2	
	14931-KT7-013	SHIM,TAPPET (1.950)	2	
	14932-KT7-013	SHIM,TAPPET (1.975)	2	
	14933-KT7-013	SHIM,TAPPET (2.000)	2	
	14934-KT7-013	SHIM,TAPPET (2.025)	2	
	14935-KT7-013	SHIM,TAPPET (2.050)	2	
	14936-KT7-013	SHIM,TAPPET (2.075)	2	
	14937-KT7-013	SHIM,TAPPET (2.100)	2	
	14938-KT7-013	SHIM,TAPPET (2.125)	2	
	14939-KT7-013	SHIM,TAPPET (2.150)	2	
	14940-KT7-013	SHIM,TAPPET (2.175)	2	
	14941-KT7-013	SHIM,TAPPET (2.200)	2	
	14942-KT7-013	SHIM,TAPPET (2.225)	2	
	14943-KT7-013	SHIM,TAPPET (2.250)	2	

BLOCK No.
E-3
CAMSHAFT/VALVE

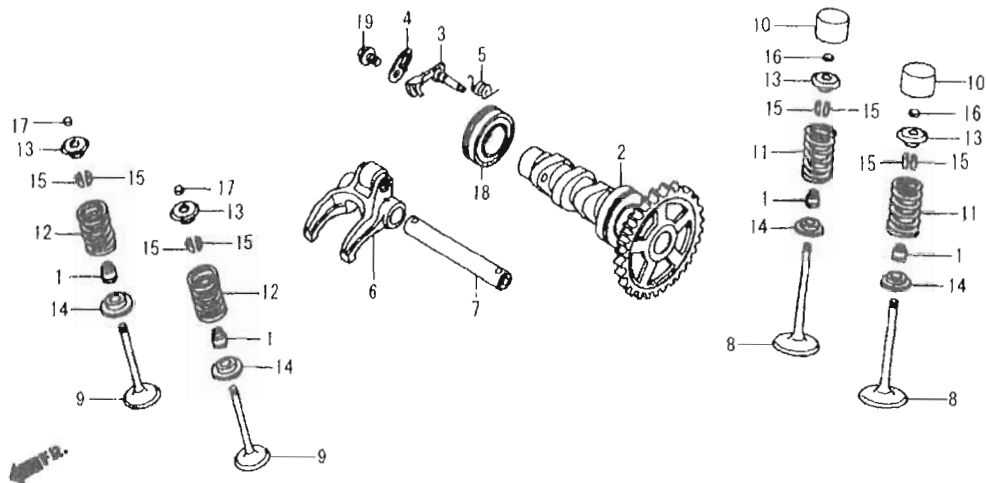

Ref. No.	Part No.	Description	Reqd. QTY
(16)	14944-KT7-013	SHIM,TAPPET (2.275)	2
	14945-KT7-013	SHIM,TAPPET (2.300)	2
	14946-KT7-013	SHIM,TAPPET (2.325)	2
	14947-KT7-013	SHIM,TAPPET (2.350)	2
	14948-KT7-013	SHIM,TAPPET (2.375)	2
	14949-KT7-013	SHIM,TAPPET (2.400)	2
	14950-KT7-013	SHIM,TAPPET (2.425)	2
	14951-KT7-013	SHIM,TAPPET (2.450)	2
	14946-KT7-013	SHIM,TAPPET (2.325)	2
	14947-KT7-013	SHIM,TAPPET (2.350)	2
	14948-KT7-013	SHIM,TAPPET (2.375)	2
	14949-KT7-013	SHIM,TAPPET (2.400)	2
	14950-KT7-013	SHIM,TAPPET (2.425)	2
	14951-KT7-013	SHIM,TAPPET (2.450)	2
17	14901-KT7-013	SHIM,TAPPET (1.200)	2
	14902-KT7-013	SHIM,TAPPET (1.225)	2
	14903-KT7-013	SHIM,TAPPET (1.250)	2
	14904-KT7-013	SHIM,TAPPET (1.275)	2
	14905-KT7-013	SHIM,TAPPET (1.300)	2
	14906-KT7-013	SHIM,TAPPET (1.325)	2
	14907-KT7-013	SHIM,TAPPET (1.350)	2
	14908-KT7-013	SHIM,TAPPET (1.375)	2
	14909-KT7-013	SHIM,TAPPET (1.400)	2
	14910-KT7-013	SHIM,TAPPET (1.425)	2
	14911-KT7-013	SHIM,TAPPET (1.450)	2
	14912-KT7-013	SHIM,TAPPET (1.475)	2
	14913-KT7-013	SHIM,TAPPET (1.500)	2
	14914-KT7-013	SHIM,TAPPET (1.525)	2
	14915-KT7-013	SHIM,TAPPET (1.550)	2

BLOCK No.
E-4
CAM CHAIN/TENSIONER

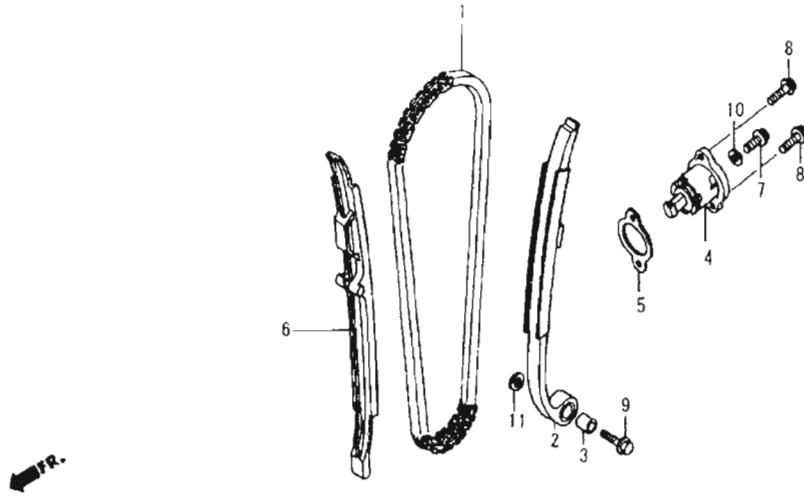

Ref. No.	Part No.	Description	Reqd. QTY	Retail Price
1	14401-KRN-671	CHAIN, CAM (104L)	1	
2	14510-KRN-670	TENSIONER COMP., CAM CHAIN	1	
3	14515-KF0-000	COLLAR, TENSIONER, 6x9	1	
4	14520-KRN-671	LIFTER ASSY., TENSIONER	1	
5	14560-MEN-671	GASKET, TENSIONER LIFTER	1	
6	14620-KRN-670	GUIDE, CAM CHAIN	1	
7	90004-GHB-600	BOLT, FLANGE, 6x10 (NSHF)	1	
8	90004-GHB-630	BOLT, FLANGE, 6x16 (NSHF)	2	
9	90088-MEB-670	BOLT, FLANGE, 6x25	1	
10	90442-397-000	WASHER, SEALING, 6MM	1	
11	90482-567-000	WASHER, SPECIAL, 6MM	1	

BLOCK No.
E-5
CYLINDER

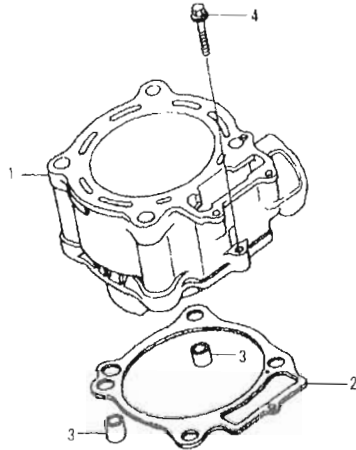

Ref. No.	Part No.	Description	Reqd. QTY	Retail Price
1	12100-KRN-731	CYLINDER	1	
2	12191-KRN-731	GASKET,CYLINDER	1	
3	94301-12200	DOWEL PIN, 12x20	2	
4	96001-06028-00	BOLT,FLANGE, 6x28	1	

BLOCK No.
E-6
R-CRANKCASE COVER

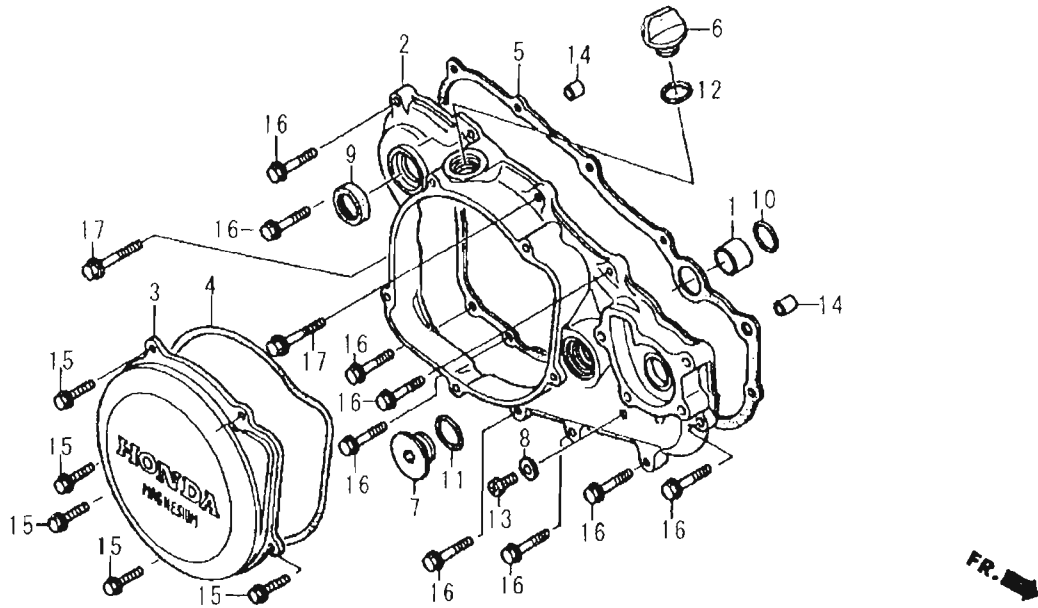

Ref. No.	Part No.	Description	Reqd. QTY	Retail Price
1	11102-KRN-670	COLLAR,WATER PASS, 16MM	1	
2	11331-KSC-670	COVER,R.CRANKCASE	1	
3	11351-KSC-A30	COVER,CLUTCH	1	
4	11352-KRN-671	GASKET,CLUCH COVER	1	
5	11394-KRN-A00	GASKET,R.COVER	1	
M 6	15611-KA3-710W	CAP,OIL FILLER	1	
7	90087-KW3-000	CAP,30MM	1	
8	90463-ML7-000	WASHER,SEALING, 6.5MM	1	
9	91205-KA3-712	OIL SEAL,16.5x25x5 (NOK)	1	
10	91304-MJ0-003	O-RING, 15.8x2.4(SHOWA)	1	
11	91305-KF0-003	O-RING, 27x2(ARAI)	1	
12	91370-461-000	O-RING, 11.9x2.2	1	
13	90004-GHB-600W	BOLT,FLANGE, 6x10(NSHF)	1	
14	94301-08140	DOWEL PIN, 8x14	2	
15	96001-06020-00	BOLT,FLANGE, 6x20	5	
16	96001-06028-00	BOLT,FLANGE 6x28	9	
17	96001-06035-00	BOLT,FLANGE, 6x35	2	

BLOCK No.
E-7
CLUTCH

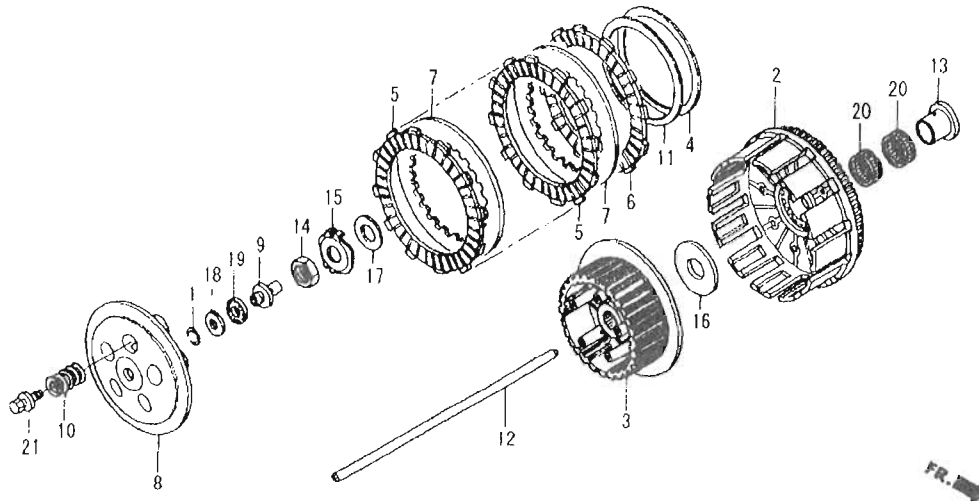

Ref. No.	Part No.	Description	Reqd. QTY	Retail Price
1	13115-147-000	CLIP, PISTON PIN, 10MM	1	
2	22100-KRN-A10	OUTER COMP., CLUTCH	1	
3	22120-KRN-A00	CENTER, CLUTCH	1	
4	22125-435-000	SEAT, JUDDER SPRING	1	
5	22201-KSC-670	DISK A, CLUTCH FRICTION	7	
6	22202-KSC-670	DISK B, CLUTCH FRICTION	1	
7	22321-KF0-770	PLATE, CLUTCH	7	
8	22351-KZ4-A90	PLATE, CLUTCH PRESSURE	1	
9	22352-KZ4-A90	PIECE, CLUTCH LIFTER	1	
10	22401-KSC-670	SPRING, CLUTCH	5	
11	22402-435-000	SPRING, JUDDER	1	
12	22851-KZ3-J20	ROD, CLUTCH LIFTER	1	
13	28237-KSC-670	COLLAR, CLUTCH OUTER	1	
14	90235-KA4-000	NUT, 18MM	1	
15	90441-KSC-670	WASHER, LOCK, 18MM	1	
16	90456-KS6-000	WASHER, THRUST, 20MM	1	
17	90501-ML3-910	WASHER, 18x32x2	1	
18	90608-072-000	WASHER, 12MM	1	
19	91001-147-003	BEARING, NEEDLE, 12MM(NTN)	1	
20	91012-P68-003	BEARING, NEEDLE, 27x31x16.8	2	
21	93404-06020-08	BOLT-WASHER, 6x20	5	

BLOCK No.
E-8
OIL PUMP

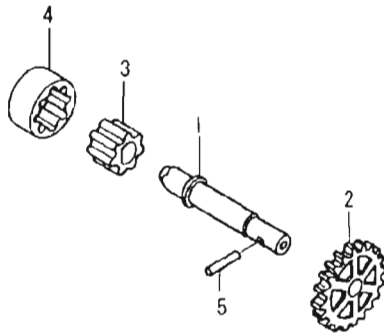

Ref. No.	Part No.	Description	Reqd. QTY	Retail Price
1	15111-KRN-670	SHAFT,OIL PUMP	1	
2	15133-KRN-670	GEAR,OIL PUMP DRIVEN (18T)	1	
3	15331-324-000	ROTOR,OIL PUMP INNER	1	
4	15332-324-000	ROTOR,OIL PUMP OUTER	1	
5	96220-30178	ROLLER, 3x17.8	1	

BLOCK No.
E-9
WATER PUMP

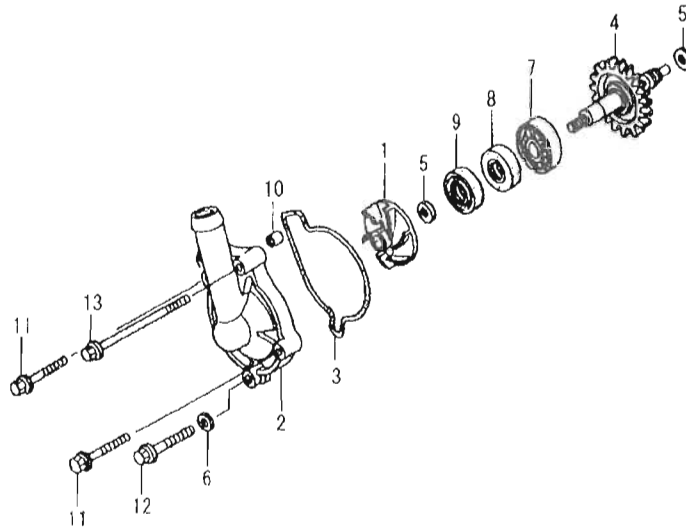

Ref. No.	Part No.	Description	Reqd. QTY	Retail Price
1	19215-KRN-A00	IMPELLER,WATER PUMP	1	
2	19221-KRN-A00	COVER,WATER PUMP	1	
3	19226-KRN-670	GASKET,WATER PUMP	1	
4	19240-KSC-670	GEAR COMP.,WATER PUMP (22T)	1	
5	90447-KE1-000	WASHER,SEALING, 7MM	1	
6	90463-ML7-000	WASHER,SEALING, 6.5MM	1	
7	91001-KA4-003	BEARING,RADIAL BALL, 12x28x7(NTN)	1	
8	91201-148-003	OIL SEAL, 12x22x5(ARAI)	1	
9	91211-KSE-671	SEAL,WATER PUMP	1	
10	94301-08100	DOWEL PIN, 8x10	1	
11	96001-06028-00	BOLT,FLANGE, 6x28	2	
M 12	96001-06028-00W	BOLT,FLANGE, 6x28	1	
13	96001-06085-00	BOLT,FLANGE, 6x85	1	

BLOCK No.
E-10
L..CRANKCASE COVER

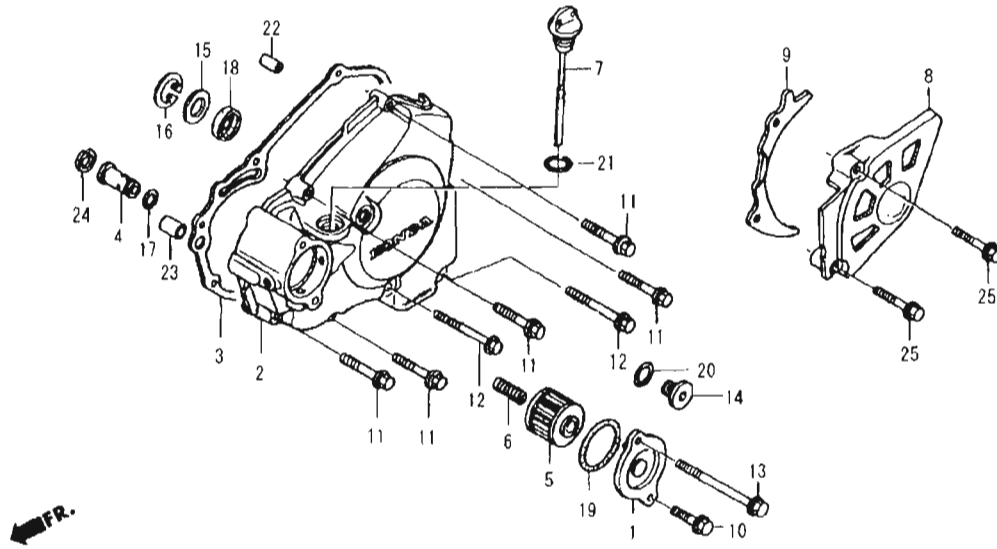

Ref. No.	Part No.	Description	Reqd. QTY	Retail Price
	1	11333-KRN-670	COVER, OIL FILTER	1
	2	11340-KSC-A30	COVER COMP., L.CRANKCASE	1
	3	11395-KRN-670	GASKET, L.COVER	1
	4	15220-MEB-770	VALVE ASSY., RELIEF	1
	5	15412-MEN-671	FILTER COMP., ENGINE OIL	1
	6	15414-MEB-670	SPRING, OIL FILTER	1
M	7	15650-KRN-670W	GAUGE, OIL LEVEL	1
M	8	23810-10512-670	COVER COMP., DRIVE SPROCKET	1
M	9	23812-10512-670	GUIDE, DRIVECHAIN	1
M	10	90004-GHB-630W	BOLT, FLANGE, 6x16 (NSHF)	1
	11	90004-GHB-690	BOLT, FLANGE, 6x32 (NSHF)	5
	12	90004-GHB-710	BOLT, FLANGE, 6x40 (NSHF)	2
M	13	90004-GHB-780W	BOLT, FLANGE, 6x75 (NSHF)	1
	14	90084-MEN-670	CAP, 14MM	1
	15	90451-459-770	WASHER, THRUST, 13MM	1
	16	90602-MEB-670	CIRCLIP, SPECIAL INTERNAL, 24MM	1
	17	90751-GK1-003	O-RING, 8.5x1.7	1
	18	91204-HP1-601	OIL SEAL, 10x21x5	1
	19	91302-PA9-003	O-RING, 39.8x2.2(ARAI)	1
	20	91303-377-000	O-RING, 13.8x2.5	1
	21	91307-035-000	O-RING, 18x3	1
	22	94301-08140	DOWEL PIN, 8x14	1
	23	94301-10160	DOWEL PIN, 10x16	1
	24	94520-14000	CIRCLIP, INTERNAL, 14MM	1
	25	96001-06030-07	BOLT, FLANGE, 6x30	2

BLOCK No.
E-11
GENERATOR

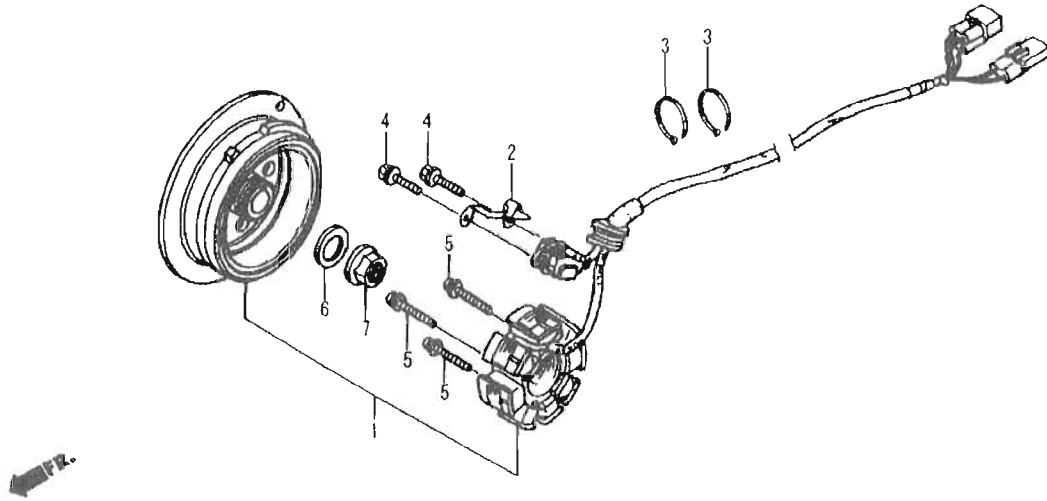

Ref. No.	Part No.	Description	Reqd. QTY	Retail Price
1	31100-KSC-A11	GENERATOR ASSY., FLYWHEEL TYPE A.C.	1	
2	32112-KRN-670	CLAMPER, CORD	1	
M 3	90650-25100-10	BAND, SELF LOCK 2.5x100 BK	3	
4	90005-896-000	BOLT, FLANGE, 5x16	2	
5	90010-MEB-670	SCREW-WASHER, 4x24	3	
6	90437-611-000	WASHER, PLAIN, 12MM	1	
7	94050-12000	NUT, FLANGE, 12MM	1	

BLOCK No.
E-12
STARTING MOTOR

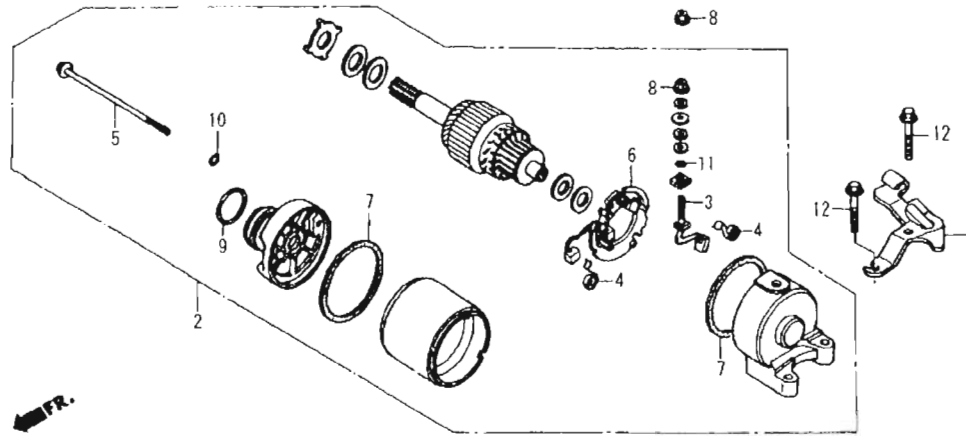

Ref. No.	Part No.	Description	Reqd. QTY	Retail Price
1	22838-KSC-670	RECEIVER,CLUTCH CABLE	1	
2	31200-KSC-671	MOTOR ASSY.,STARTING	1	
3	31201-MBE-008	TERMINAL SET,BRUSH	1	
4	31204-KS5-901	SPRING, CABON BRUSH	2	
5	31205-MBE-008	BOLT,SETTING	2	
6	31206-MBE-008	HOLDER SET,BRUSH	1	
7	31207-MBE-008	RING	2	
8	90071-MB0-000	NUT-WASHER, 6MM	2	
9	91309-425-003	O-RING, 24.4x3.1(ARAI)	1	
10	91320-MBE-008	O-RING	2	
11	91320-MB0-000	O-RING	1	
12	96001-06028-00	BOLT,FLANGE 6x28	2	

BLOCK No.
E-13
STARTING CLUTCH

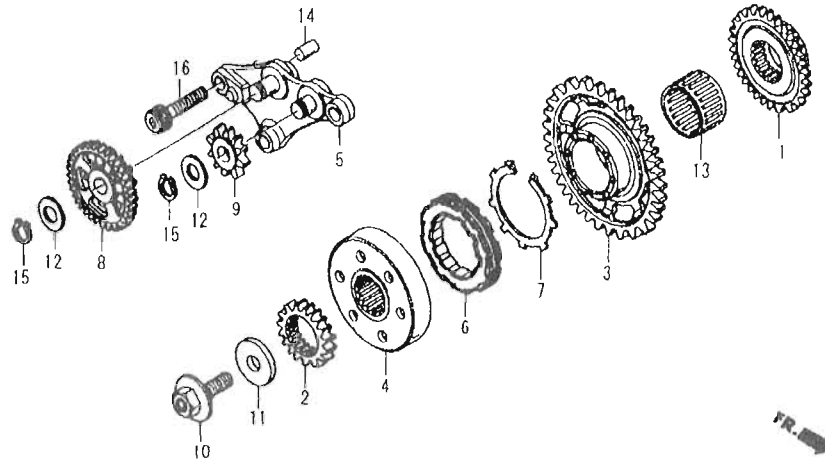

Ref. No.	Part No.	Description	Reqd. QTY	Retail Price
1	13415-KRN-670	GEAR,BALANCER DRIVE (32T)	1	
2	23121-KSC-670	GEAR,PRIMARY DRIVE (18T)	1	
3	28110-KSC-670	GEAR COMP.,STARTING DRIVEN (38T)	1	
4	28115-KSC-670	OUTER,STARTING CLUTCH	1	
5	28120-KSC-670	HOLDER COMP.,STARTER GEAR	1	
6	28125-MT7-004	CLUTCH, ONE WAY	1	
7	28127-MS2-612	RING,FRICTION	1	
8	28131-KSC-670	GEAR,STARTING REDUCTION (53T/10T)	1	
9	28141-KSC-670	GEAR,STARTING IDLE (10T)	1	
10	90013-MEB-670	BOLT,SPECIAL, 12x28	1	
11	90402-KW6-960	WASHER,PLAIN, 12MM	1	
12	90452-166-600	WASHER,THRUST, 12MM	2	
13	91025-KT7-003	BEARING,NEEDLE, 30x35x20	1	
14	94303-08140	DOWEL PIN, 8x14	1	
15	94510-12000	CIRCLIP,EXTERNAL, 12MM	2	
16	96600-08028-00	BOLT,SOCKET, 8x28	3	

BLOCK No.
E-14
CRANKCASE

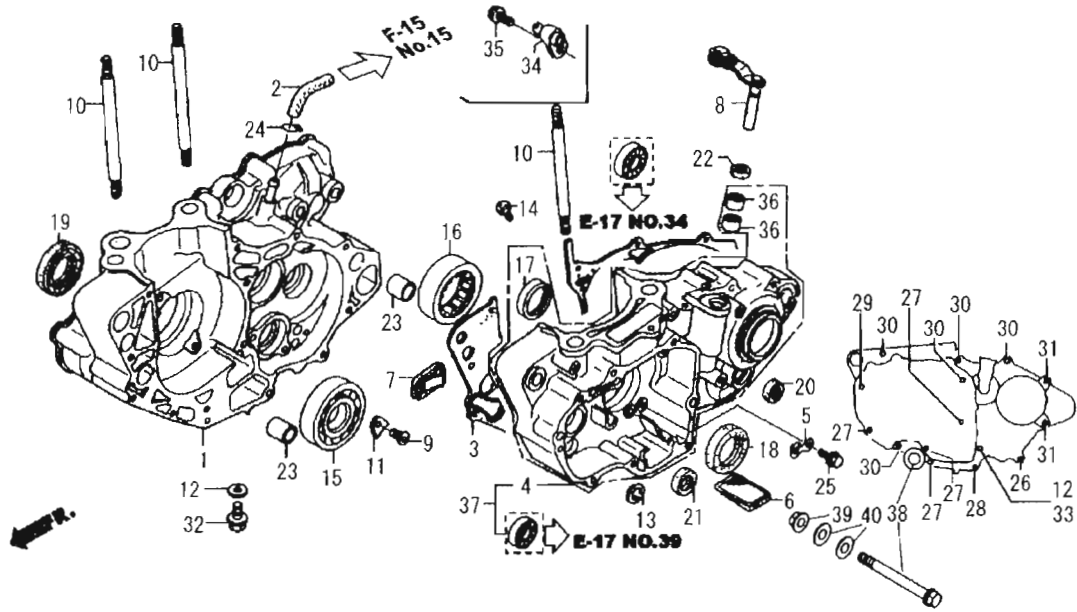

Ref. No.	Part No.	Description	Reqd. QTY	Retail Price
M 1	11100-10512-A20	CRANKCASE COMP., R.	1	
2	11105-KSC-670	TUBE A, BREACHER	1	
3	11191-KRN-A10	GASKET, CRANKCASE	1	
M 4	11200-10512-A20	CRANKCASE COMP., L.	1	
5	11206-KRN-670	PLATE, CAM CHAIN GUIDE	1	
6	15421-KK0-000	SCREEN, OIL FILTER	1	
7	18601-MBW-003	VALVE COMP., REED	1	
8	22810-KSC-A10	LEVER COMP., CLUTCH LIFTER	1	
9	90001-MEN-850	SCREW, SPECIAL FLAT, 6x17	2	
10	90031-KRN-670	BOLT, STUD, 10x135	4	
11	90441-KRN-670	PLATE, BREARING HOLDER	2	
12	90474-333-000	WASHER, SEALING, 8MM	2	
13	90604-MEB-670	CIRCLIP, SPECIAL, 33MM	1	
14	90901-KSC-A20	ORFICE, #170	1	
15	91001-KRN-671	BEARING, RADIAL BALL, 30x72x16	1	
16	91002-KRN-A11	BEARING, SPECIAL ROLLER	1	
17	91022-KA4-740	BEARING, SHELL, 33x38x8 (NTN)	1	
18	91201-MEB-671	OIL SEAL, 38x52x7(ARAI)	1	
19	91202-MEY-671	OIL SEAL, 39x56x7.5(ARAI)	1	
20	91203-KA4-771	OIL SEAL, 14x22x5(NOK)	1	
21	91203-MEB-671	OIL SEAL, 20x33x5(ARAI)	1	
22	91205-MEB-671	OIL SEAL, 12x18x3(ARAI)	1	
23	94301-14200	DOWEL PIN, 14x20	2	
24	95002-02100	CLIP, TUBE (B10)	1	
25	96001-06012-00	BOLT, FLANGE, 6x12	1	

BLOCK No.
E-14
CRANKCASE

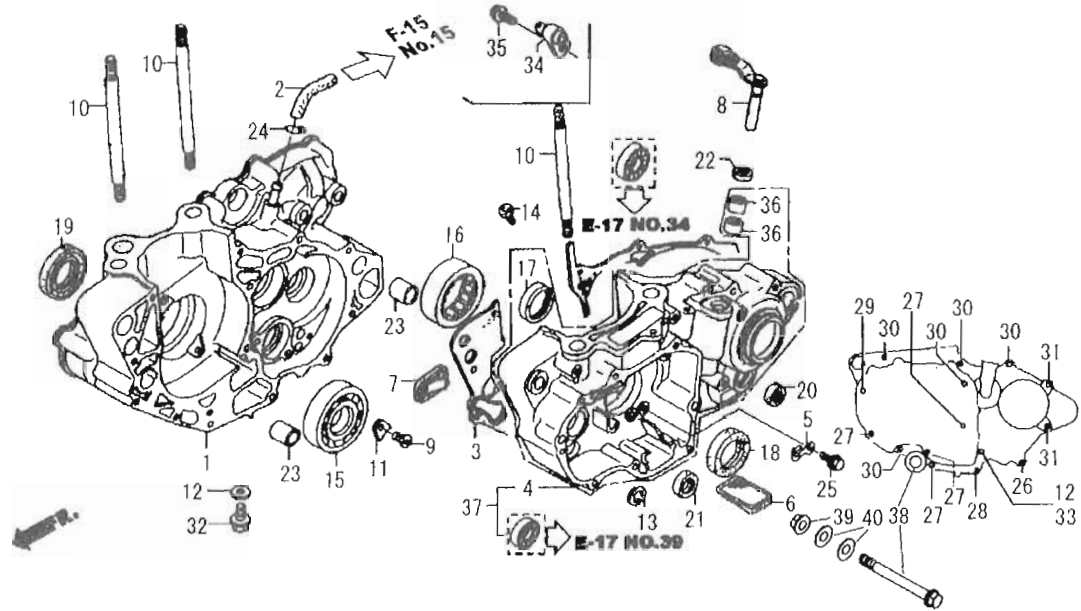

Ref. No.	Part No.	Description	Reqd. QTY	Retail Price
	26	96001-06040-00 BOLT, FLANGE, 6x40	1	
	27	96001-06045-00 BOLT, FLANGE, 6x45	4	
M	28	96001-06045-00W BOLT, FLANGE, 6x45	1	
	29	96001-06060-00 BOLT, FLANGE, 6x60	1	
	30	96001-06070-00 BOLT, FLANGE, 6x70	5	
	31	96001-06075-00 BOLT, FLANGE, 6x75	2	
M	32	96300-08025-00W BOLT, FLANGE, 8x25	1	
M	33	96300-08070-00W BOLT, FLANGE, 8x70	1	
	34	11210-KRN-730 JET COMP., PISTON, #80	1	
	35	96001-06012-00 BOLT, FLANGE, 6x12	1	
	36	91053-719-005 BEARING, NEEDLE, 12x16x10(NTN)	2	
	37	11200-KSC-315 CRANKCASE SET, L.	1	
M	38	9170-10125-1610 BOLT, FLANGE, 10x125	1	
	39	90304-GA6-003 NUT, FLANGE, 10	1	
M	40	94103-10026-90 WASHER, 10	2	

BLOCK No.
E-15
CRANKSHAFT/PISTON

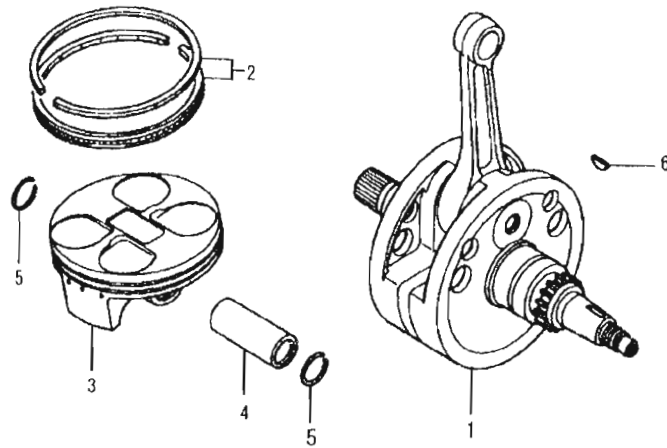

Ref. No.	Part No.	Description	Reqd. QTY	Retail Price
1	13000-KSC-A10	CRANKSHAFT COMP.	1	
2	13011-KRN-850	RING SET,PISTON (STD.)	1	
3	13101-KRN-850	PISTON	1	
4	13111-KRN-850	PIN,PISTON	1	
5	13115-KM7-700	CLIP,PISTON PIN, 16MM	2	
6	13331-360-000	KEY,SPECIAL WOODRUFF, 25x14	1	

BLOCK No.
E-16
BALANCER

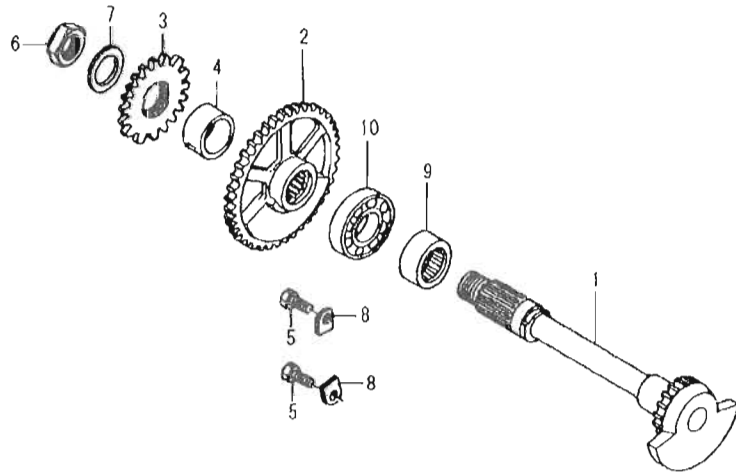

Ref. No.	Part No.	Description	Reqd. QTY	Retail Price
1	13420-KSC-A10	SHAFT COMP.,BALANCER	1	
2	13422-KRN-A00	GEAR,BALANCER DRIVEN (32T)	1	
3	19245-KRN-671	GEAR,WATER PUMP DRIVE (19T)	1	
4	19246-KSC-670	COLLAR,WATER PUMP GEAR	1	
5	90038-KY4-900	BOLT,HEX., 6x16	2	
6	90204-MN5-000	NUT,HEX., 14MM	1	
7	90433-KE1-000	WASHER, 14MM	1	
8	90441-KA4-700	PLATE,BEARING HOLDER	2	
9	91004-MEB-671	BEARING, SPECIAL ROLLER, 20x32x14	1	
10	91005-MEB-671	BEARING, RADIAL BALL, TMB 6003	1	

BLOCK No.
E-17
TRANSMISSION

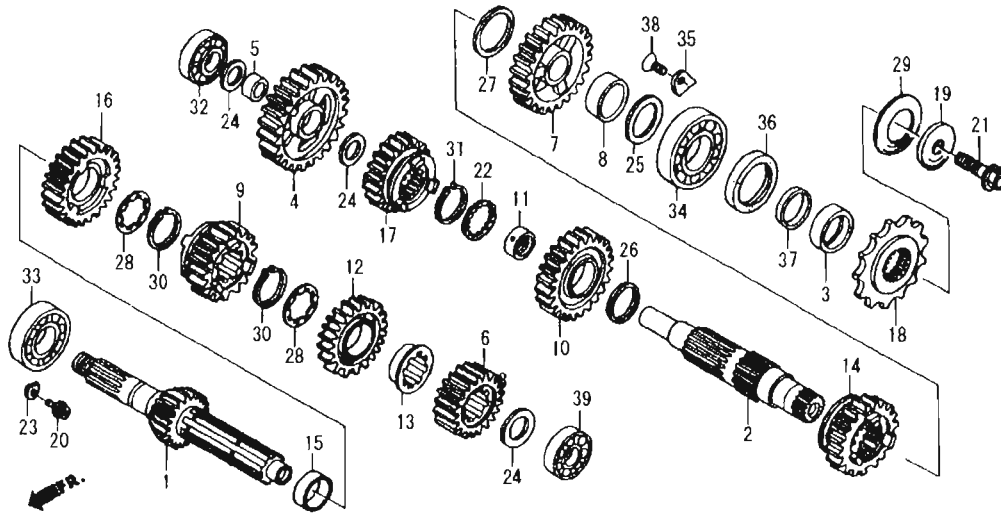

Ref. No.	Part No.	Description	Reqd. QTY	Retail Price
1	23210-KSC-A10	SHAFT COMP.,MAIN (13T)	1	
2	23221-KSC-A10	COUNTERSHAFT COMP.	1	
3	23225-KSC-670	COLLAR,COUNTERSHAFT	1	
4	23411-KSC-670	GEAR,COUNTERSHAFT LOW (31T)	1	
5	23413-KSC-670	COLLAR, 17MM	1	
6	23421-KSC-670	GEAR,MAINSHAFT SECOND (16T)	1	
7	23431-KSC-670	GEAR,COUNTERSHAFT SECOND (28T)	1	
8	23432-KSC-670	COLLAR, 24MM	1	
9	23441-KSC-670	GEAR,MAINSHAFT THIRD (21T)	1	
10	23451-KSC-670	GEAR,COUNTERSHAFT THIRD (28T)	1	
11	23452-KSC-670	COLLAR,COUNTERSHAFT THIRD GEAR	1	
12	23461-KSC-670	GEAR,MAINSHAFT FOURTH (24T)	1	
13	23462-KSC-670	COLLAR,MAINSHAFT FOURTH GEAR	1	
14	23471-KSC-670	GEAR,COUNTERSHAFT FOURTH (25T)	1	
15	23472-KZ4-000	COLLAR,20MM	1	
16	23481-KSC-670	GEAR,MAINSHAFT FIFTH (27T)	1	
17	23491-KSC-670	GEAR,COUNTERSHAFT FIFTH (22T)	1	
M 18	23804-10512-00	SPROCKET,DRIVE (17T)	1	
M	23805-10512-00	SPROCKET,DRIVE (18T)	(1)	
19	23802-KSC-670	COLLAR,DRIVE SPROCKET	1	
20	90071-MF5-000	BOLT,FLANGE SOCKET, 6x14	2	
21	90112-413-000	BOLT,UBS, 8x33	1	
22	90404-KW3-000	WASHER,THRUST INVOLUTE, 22x21x1	1	
23	90441-KA4-700	PLATE,BEARING HOLDER	2	
24	90446-357-000	WASHER,THRUST, 17.2MM	3	
25	90453-KSR-A00	WASHER, 22x32x1.5	1	
26	90452-KZ4-000	WASHER,THRUST, 22x30x1	1	
27	90452-KSR-A00	WASHER, 24x32x1	1	

BLOCK No.
E-17
TRANSMISSION

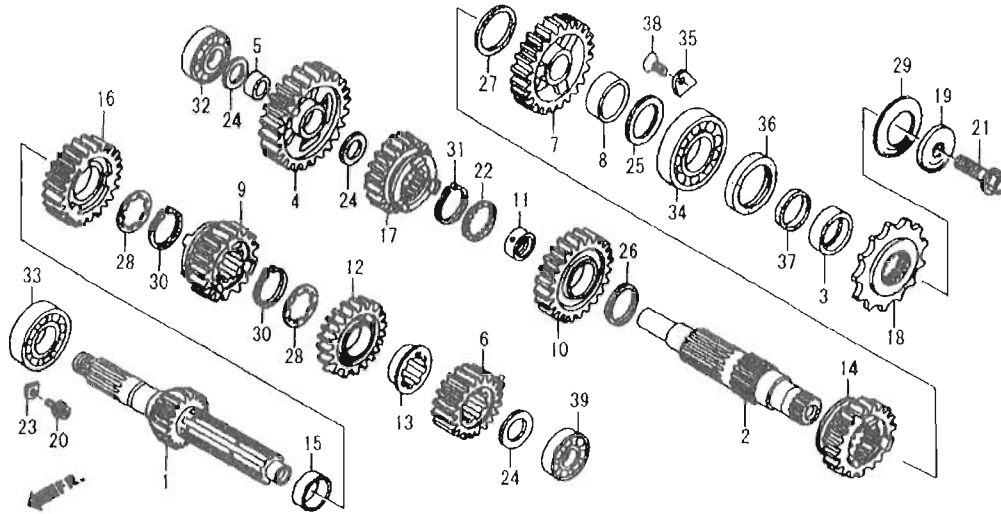

Ref. No.	Part No.	Description	Reqd. QTY	Retail Price
28	90455-HM8-A40	WASHER, SPLINE, 20MM	2	
29	90501-KSC-670	WASHER, SPRING, 24MM	1	
30	90601-360-000	SET RING, 20MM	2	
31	90602-360-000	SET RING, 22MM	1	
32	91001-KZ4-J11	BEARING, RADIAL BALL, 17x35x10	1	
33	91004-KSC-671	BEARING, RADIAL BALL, 22x47x14	1	
34	91005-KRN-A01	BEARING, RADIAL BALL, 22x52x14	1	
35	91012-KA3-710	PLATE, COUNTERSHAFT BEARING	2	
36	91201-KSR-A01	OIL SEAL, 28x37x7	1	
37	91301-KSR-A01	D-RING, 22MM	1	
38	93600-06010-0H	SCREW, FLAT, 6x10	2	
39	91006-KRN-A01	BEARING RADIAL BALL, 17x38x10	1	

BLOCK No.
E-18
GEARSHIFT DRUM

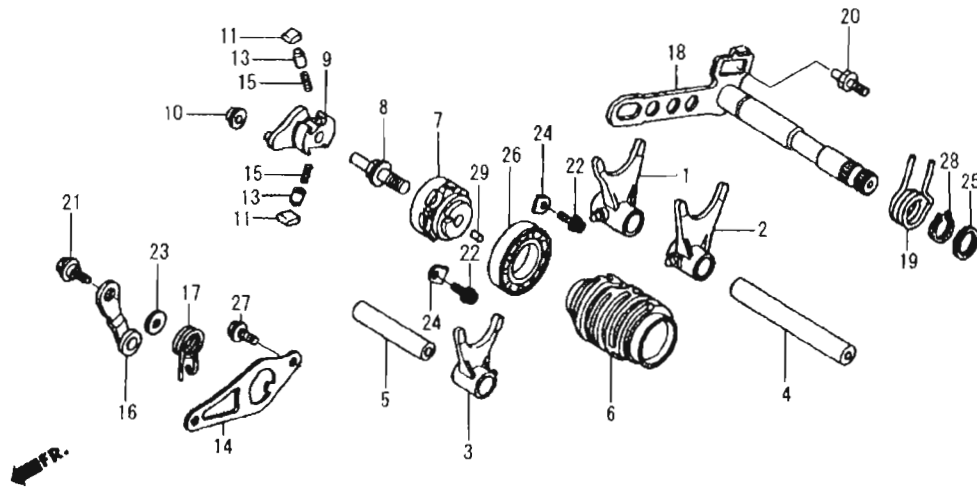

Ref. No.	Part No.	Description	Reqd. QTY	Retail Price
1	24211-KSC-670	FORK,R.GEARSHIFT	1	
2	24221-KSC-670	FORK,L.GEARSHIFT	1	
3	24231-KSC-670	FORK C,GEARSHIFT	1	
4	24241-KSC-670	SHIFT A,SHIFT FORK	1	
5	24242-KSC-670	SHIFT B,SHIFT FORK	1	
6	24311-KRN-A00	DRUM,GEARSHIFT	1	
7	24312-KA3-741	CENTER,GEARSHIFT DRUM	1	
8	24315-HA0-000	PIN,SHIFTER	1	
9	24321-KZ4-620	SHIFTER,DRUM	1	
10	24322-MM4-000	COLLAR,SHIFTER	1	
11	24324-KA3-711	PAWL A,RATCHET	1	
12	24325-KA3-711	PAWL B,RATCHET	1	
13	24326-KBH-901	PLUNGER,PAWL	2	
14	24328-KRN-670	PLATE,GUIDE	1	
15	24329-KA3-740	SPRING,PAWL PLANGER	2	
16	24430-KA3-740	STOPPER COMP.,DRUM	1	
17	24435-KZ4-690	SPRING,DRUM STOPPER	1	
18	24610-KRN-730	SPINDLE COMP.,GEARSHIFT	1	
19	24651-MEB-670	SPRING,GEARSHIFT RETURN	1	
20	24652-HA0-000	PIN,GEARSHIFT RETURN SPRING	1	
21	90022-MG8-000	PIVOT,SHIFT DRUM STOPPER ARM	1	
22	90071-MF5-000	BOLT,FLANGE SOCKET, 6x14	2	
23	90435-HB3-000	WASHER, 6.1MM	1	
24	90441-KA4-700	PLATE,BEARING HOLDER	2	
25	90451-155-000	WASHER, 14MM	1	
26	91004-KY4-900	BEARING, RADIAL BALL, 6905U	1	
27	93301-06016-0A	BOLT,HEX., 6x16	2	
28	94510-14000	CIRCLIP,EXTERNAL, 14MM	1	
29	96220-40080	ROLLER, 4x8	1	

BLOCK No.
E-19
KICK STARTER SPINDLE

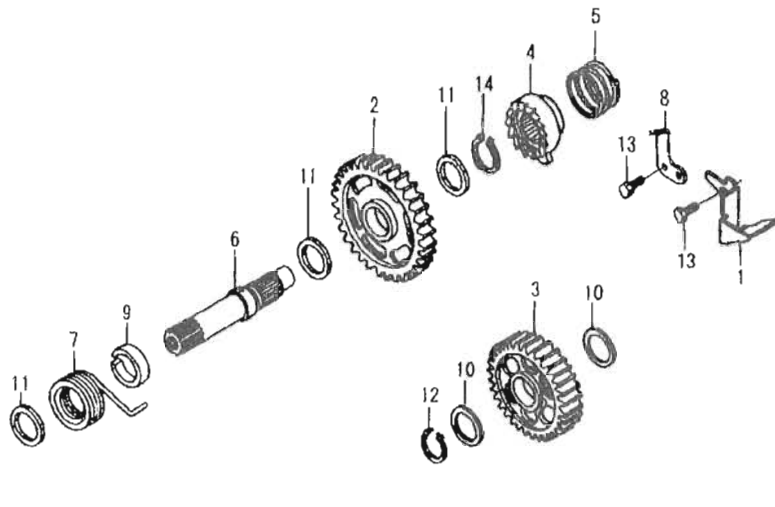

Ref. No.	Part No.	Description	Reqd. QTY	Retail Price
1	15201-KSC-670	PLATE,OIL GUIDE	1	
2	28210-KSC-670	PINION COMP.,KICK STARTER (32T)	1	
3	28230-KRN-670	GEAR COMP.,STARTER IDLE (30T)	1	
4	28241-KA3-710	RATCHET,STARTER	1	
5	28242-KA3-710	SPRING RATCHET	1	
6	28251-KZ4-000	SPINDLE,KICK STARTER	1	
7	28261-KA3-710	SPRING STARTER RETURN	1	
8	28262-KS6-701	PLATE,RATCHET SLIDER	1	
9	28282-KZ4-B00	COLLAR,KICK SPINDLE	1	
10	90452-178-000	WASHER<THRUST, 17MM	2	
11	90501-444-000	WASHER, 16.8x24	3	
12	90601-001-000	CIRCLIP,EXTERNAL, 17MM	1	
13	93301-06016-0A	BOLT,HEX., 6x16	2	
14	94510-16000	CIRCRIP,EXTERNAL,16MM	1	

BLOCK No.
E-20
CARBURETOR

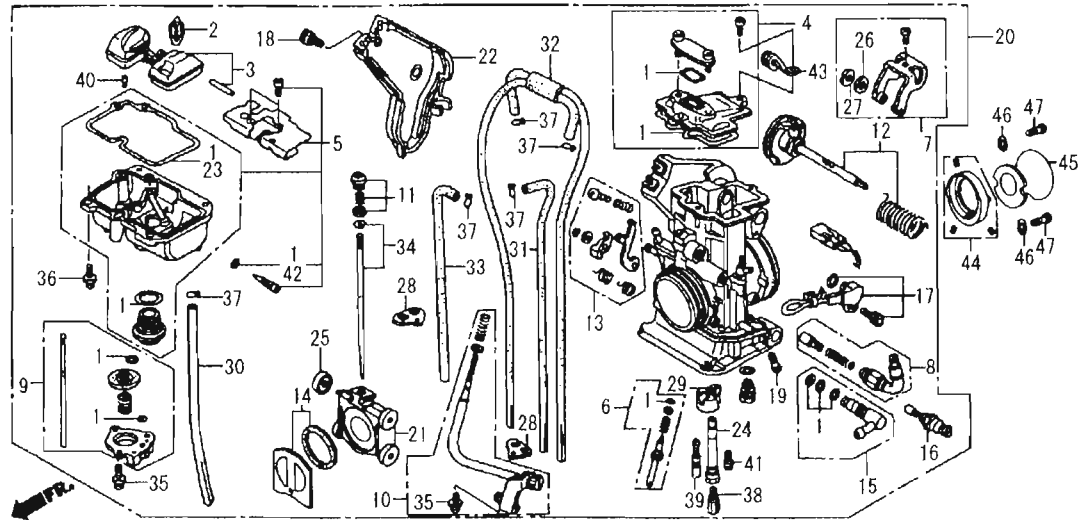

Ref. No.	Part No.	Description	Reqd .QTY	Retail Price
1	16010-KSC-671	GASKET SET	1	
2	16011-MEN-851	VALVE SET,FROAT	1	
3	16013-KRN-851	FLOAT SET	1	
4	16014-KRN-A01	TOP SET	1	
5	16015-KRN-A01	CHAMBER SET,FLOAT	1	
6	16016-KRN-A01	SCREW SET A	1	
7	16018-MEY-A11	ARM SET,LINK	1	
8	16019-MEB-671	START SET,HOT	1	
9	16021-MEN-A01	DIAPHRAGM SET,PUMP	1	
10	16028-MEN-A01	SCREW SET B	1	
11	16029-MEY-A11	SCREW SET,JETNEEDLE	1	
12	16032-KRN-A11	SHAFT SET THROTTLE	1	
13	16033-MEN-A01	LEVER SET,PUMP	1	
14	16037-MEB-671	VALVE SET,FROATING	1	
15	16038-KRN-671	JOINT SET,FUEL	1	
16	16046-MEB-671	VALVE SET,STARTER	1	
17	16060-KRN-671	SENSOR ASSY.,THROTTLE	1	
18	16080-HP1-601	BOLT,COVER	1	
19	16083-MEB-671	SCREW,PAN	1	
20	16100-KRN-A32	CARBURETOR ASSY. (FCR01F A)	1	
21	16112-HP1-A01	VALVE,THROTTLE	1	
22	16157-MEN-A01	COVER,THROTTLE	1	
23	16163-MEB-671	GASKET,FLOAT CHAMBER	1	
24	16165-MEN-A01	HOLDER,NEEDLE JET	1	
25	16172-MEB-671	ROLLER	1	
26	16177-MEB-671	WASHER,PLAIN (PO)	1	
27	16178-MEB-671	WASHER,PLAIN (SUS)	1	
28	16178-MEN-851	BINDER	2	
29	16185-KRN-851	PLATE,BUFFER	1	

BLOCK No.
E-20
CARBURETOR

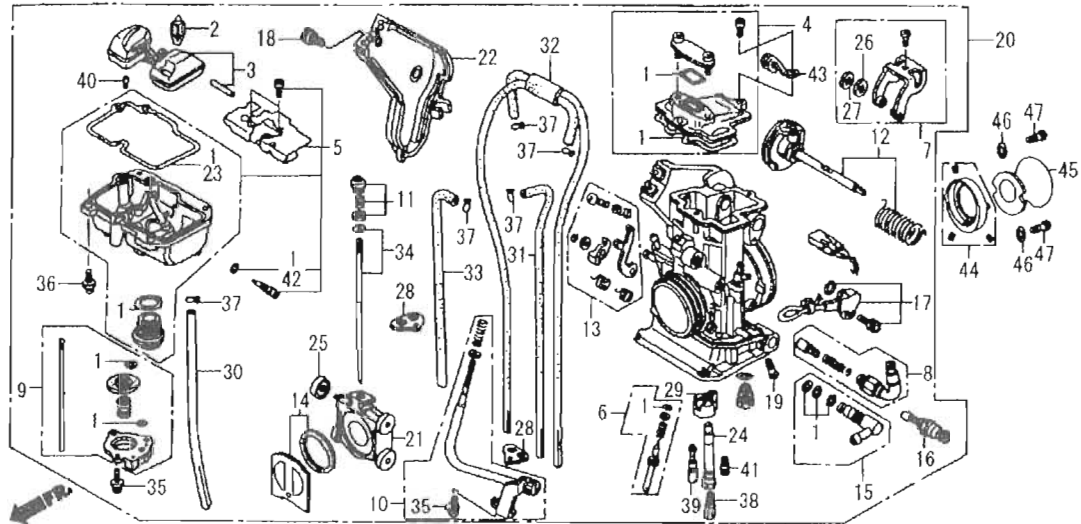

Ref. No.	Part No.	Description	Reqd .QTY	Retail Price
30	16196-MEN-851	TUBE,OVERFLOW	1	
31	16197-MEB-671	TUBE,AIR VENT	1	
32	16198-MEB-671	TUBE COMP.,AIR VENT	1	
33	16199-MEB-671	TUBE,AIR VENT	1	
34	16202-KRN-A31	NEEDLE SET,JET (NNSS)	(1)	
	16203-KRN-A31	NEEDLE SET,JET (NNST)	(1)	
	16204-KRN-A31	NEEDLE SET,JET (NNSU)	1	
	16205-KRN-A31	NEEDLE SET,JET (NNSV)	(1)	
	16206-KRN-A1	NEEDLE SET,JET (NNSW)	(1)	
	16230-KRN-A31	NEEDLE SET,JET (NNWS)	(1)	
	16231-KRN-A31	NEEDLE SET,JET (NNWT)	(1)	
	16232-KRN-A31	NEEDLE SET,JET (NNWU)	(1)	
	16233-KRN-A31	NEEDLE SET,JET (NNWV)	(1)	
	16234-KRN-A31	NEEDLE SET,JET (NNWW)	(1)	
35	93892-04008-18	SCREW-WASHER, 4x8	4	
36	93892-04014-18	SCREW-WASHER, 4x14	4	
37	95002-02079	CLIP,TUBE (B7)	5	
38	99101-357-1500	JET,MAIN, #150	(1)	
	99101-357-1520	JET,MAIN, #152	(1)	
	99101-357-1550	JET,MAIN, #155	(1)	
	99101-357-1580	JET,MAIN, #158	(1)	
	99101-357-1600	JET,MAIN, #160	(1)	
	99101-357-1620	JET,MAIN, #162	(1)	
	99101-357-1650	JET,MAIN, #165	1	
	99101-357-1680	JET,MAIN, #168	(1)	
	99101-357-1700	JET,MAIN, #170	(1)	

BLOCK No.
E-20-1
CARBURETOR,O,P,KIT

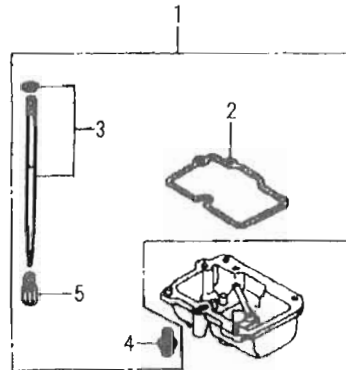
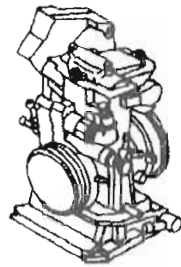

Ref. No.	Part No.	Description	Reqd. QTY	Retail Price
1	16020-KRN-A32	PARTS KIT,CARBURETIOR,OPTIONAL	(1)	
2	16163-MEB-671	GASKET,FLOAT CHAMBER	(5)	
3	16202-KRN-A31	NEEDLE SET,JET, (NNSS)	(1)	
	16203-KRN-A31	NEEDLE SET,JET, (NNST)	(1)	
	16205-KRN-A31	NEEDLE SET,JET, (NNSV)	(1)	
	16206-KRN-A31	NEEDLE SET,JET, (NNSW)	(1)	
	16230-KRN-A31	NEEDLE SET,JET, (NNWS)	(1)	
	16231-KRN-A31	NEEDLE SET,JET, (NNWT)	(1)	
	16232-KRN-A31	NEEDLE SET,JET, (NNWU)	(1)	
	16233-KRN-A31	NEEDLE SET,JET, (NNWV)	(1)	
	16234-KRN-A31	NEEDLE SET,JET, (NNWW)	(1)	
4	93892-04014-18	SCREW,WASHER 4x14	(10)	
5	99101-357-1750	JET,MAIN, #175	(1)	
	99101-357-1780	JET,MAIN, #178	(1)	
	99101-357-1800	JET,MAIN, #180	(1)	
	99101-357-1820	JET,MAIN, #182	(1)	
	99101-357-1880	JET,MAIN, #188	(1)	
	99101-357-1900	JET,MAIN, #190	(1)	
	99101-357-1920	JET,MAIN, #192	(1)	
	99101-357-1950	JET,MAIN, #195	(1)	

BLOCK No.
F-1
METER,
PANEL,METER

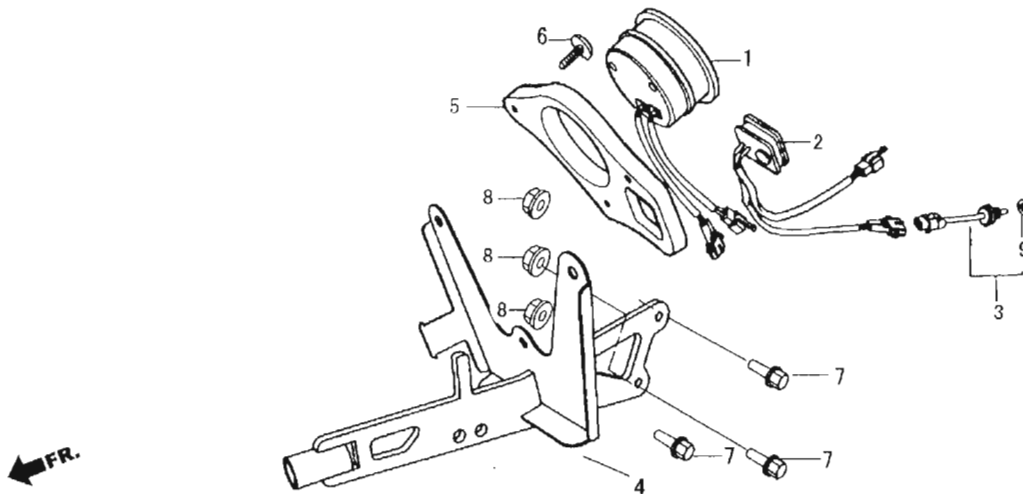

Ref. No.	Part No.	Description	Reqd. QTY	Retail Price
M 1	37250-10516-00	TACHOMETER ASSY	1	
M 2	37460-10512-00	INDICATOR ASSY., WATER TEMP	1	
M 3	37870-10512-00	SENSOR ASSY., T.W	1	
M 4	50810-10512-00	STAY COMP., CENTER FRONT COWL	1	
· 5	50815-NX4-000	PANEL, METER	1	
· 6	50816-NX4-000	CLIP, XMAS TREE	3	
7	96001-0602000	FLANGE BOLT M6x20	3	
8	90301-473-003	FLANGE LOCK NUT M6	3	
9	91307-PK2-005	O-RING, 1.5x9.5	1	

BLOCK No.
F-2
CABLE • SWITCH •
HANDLE PIPE • THROTTLE

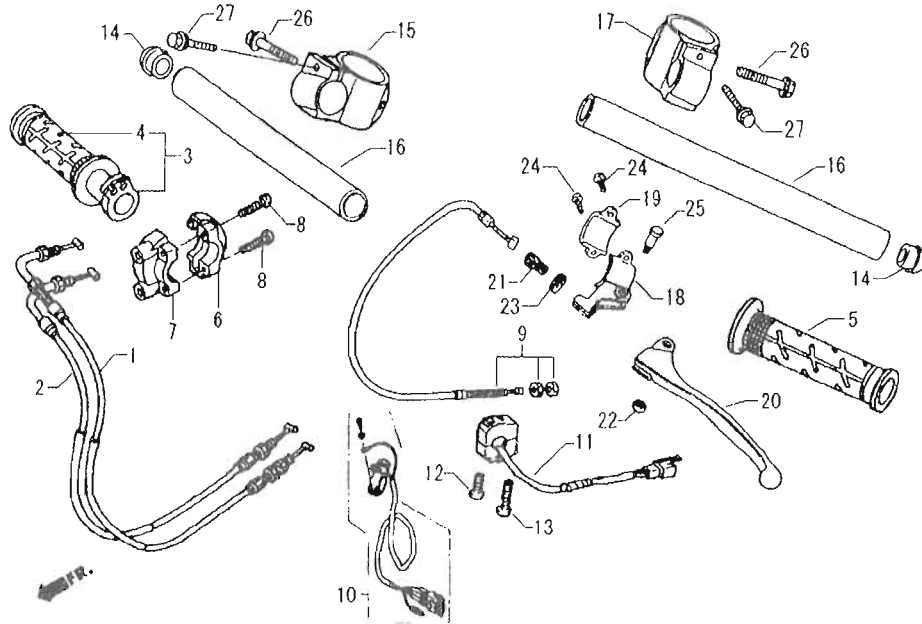

Ref. No.	Part No.	Description	Reqd. QTY	Retail Price
1	17910-MEL-000	CABLE COMP. A, THROTTLE	1	
2	17920-MEL-000	CABLE COMP. B, THROTTLE	1	
3	53140-MCF-000	GRIP ASSY., THROTTLE	1	
4	53165-MY9-890	GRIP, R. HANDLE	1	
5	53166-MY9-890	GRIP, L.. HANDLE	1	
6	53167-MV4-000	HOUSING, UPPER THROTTLE	1	
7	53168-MV4-000	HOUSING, UNDER THROTTLE	1	
8	93500-05020-0G	SCREW, PAN 5x20	2	
9	22870-MEE-010	CABLE COMP., CLUTCH	1	
M 10	35130-10512-670	SWITCH ASSY., ENGINE STOP	1	
11	35130-NL6-000	SW ASSY, ST ENGINE STOP	1	
12	93500-04030-0G	SCREW, PAN 4x30	1	
13	93500-04045-0G	SCREW, PAN 4x45	1	
M 14	53105-20158-00	CAP, HANDLE PIPE	2	
M 15	53110-10516-00	HOLDER, R. HANDLE	1	
M 16	53115-10512-00	PIPE, HANDLE	2	
M 17	53120-10516-00	HOLDER, L.. HANDLE	1	
18	53172-430-003	BRACKET, L.HANDLE LEVER	1	
19	53173-376-000	HOLDER, LEVER BRACKET	1	
20	53178-399-700	LEVER, L.STEERING HANDLE	1	
21	53192-MEE-000	BOLT, WIRE ADJUST	1	
22	90302-NX5-000	U-NUT, HEX., 6MM	1	
23	90321-MEE-000	NUT, FIXING	1	
24	93500-05016-0A	SCREW, PAN 5x16	2	
25	90114-310-000	BOLT, HANDLE LEVER PIVOT	1	
26	95801-08030-00	BOLT, FLANGE, 8x30	2	
27	96001-06022-00	BOLT, FLANGE, SH, 6x22	2	

BLOCK No.
F-3
FRONT BRAKE CALIPER
FRONT BRAKE MASTERCYLINDER

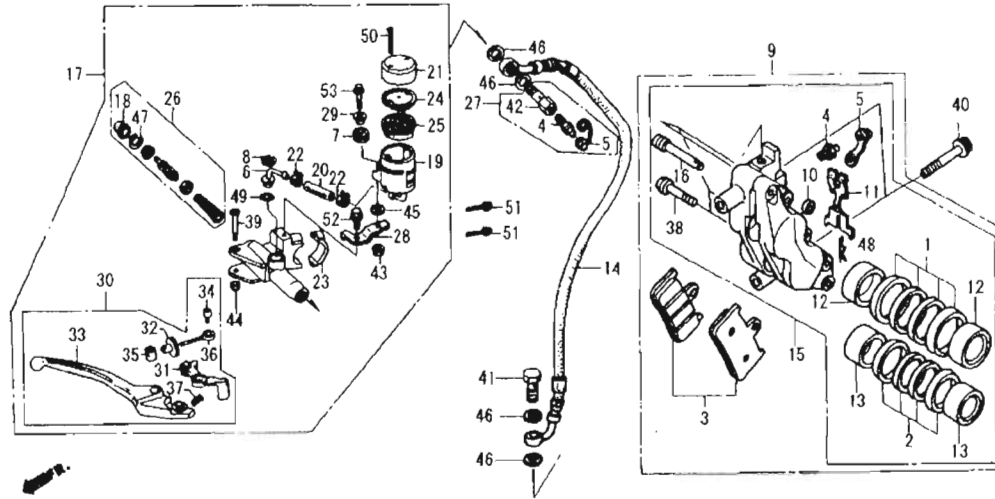

Ref. No.	Part No.	Description	Reqd. QTY	Retail Price
• 1	06451-NX4-860	SEAL SET, PISTON 34	1	
• 2	06452-NX4-860	SEAL SET, PISTON 30	1	
• 3	06455-NX4-860	PAD SET, FR	1	
4	43352-568-003	SCREW, BLEEDER	2	
5	43353-461-771	CAP, BLEEDER	2	
6	43503-KS6-701	CONNECTOR	1	
7	43516-HA2-000	RUBBER, OIL CUP MOUNT	1	
8	43517-KS6-701	CIRCLIP, REAR MASTERCYLINDER	1	
• 9	45100-NX4-861	CALIPER ASSY., R. FRONT	1	
10	45103-MR7-006	SEAL, JOINT	1	
• 11	45106-NX4-860	SPRING, PAD	1	
• 12	45107-NX4-860	PISTON, B	2	
13	45117-MR7-006	PISTON, A	2	
• 14	45125-NX4-861	HOSE, FRONT BRAKE	1	
• 15	45150-NX4-860	CALIPER SUB ASSY., R. FR	1	
• 16	45215-NX4-860	PIN, HANGER	1	
• 17	45500-NX4-861	MASTERCYLINDER ASSY., FRONT BRAKE	1	
18	45504-410-003	BOOT COMP	1	
19	45511-KV3-016	OIL CUP COMP	1	
• 20	45512-NX4-861	HOSE, MASTERCYLINDER OIL CUP	1	
21	45513-KV3-006	CAP, OIL CUP	1	
22	45514-KV3-006	CLAMP, MASTERCYLINDER OIL HOSE	2	
23	45517-166-006	HOLDER, MASTERCYLINDER	1	
24	45518-KV3-006	PLATE, DIAPHRAGM	1	
25	45520-KV3-006	DIAPHRAGM	1	
26	45530-471-831	CYLINDER SET, MASTER	1	
• 27	45530-NF4-650	BOLT ASSY., OIL BLEEDER	1	
• 28	45550-NX4-860	STAY, MASTERCYLINDER CUP	1	
29	50324-425-010	COLLAR, 6.3x13	1	

BLOCK No.
F-3
FRONT BRAKE CALIPER
FRONT BRAKE MASTERCYLINDER

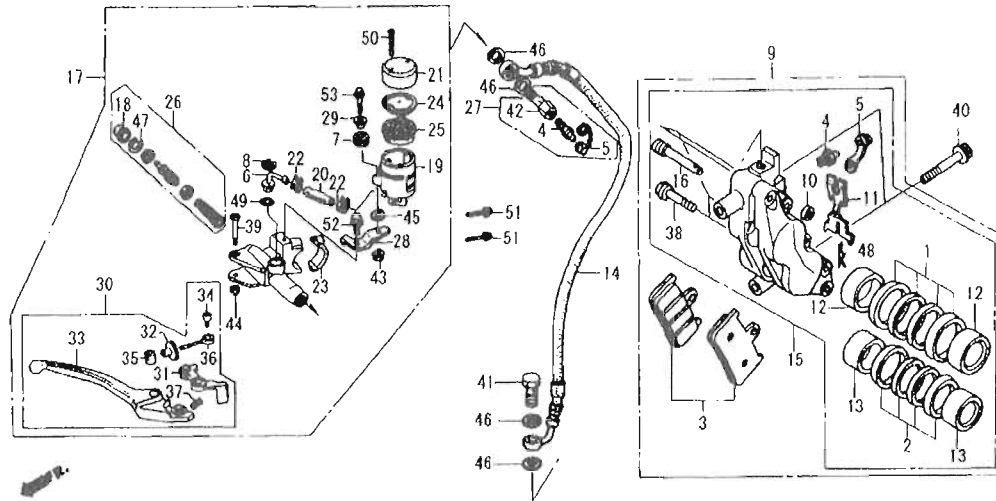

Ref. No.	Part No.	Description	Reqd. QTY	Retail Price
30	53170-MW0-006	LEVER ASSY., R. HANDLE	1	
• 31	53171-MW0-006	KNOCKER, MASTERCYLINDER	1	
32	53172-KV0-006	ADJUSTER, HANDLE LEVER R.	1	
• 33	53175-MW0-006	LEVER, HANDLE R.	1	
34	53177-KV0-006	BOLT, LEVER SOCKET, 5x5	1	
35	53179-KV0-006	JOINT, LEVER	1	
36	53180-KV0-006	BOLT, ADJUST	1	
37	53181-KV0-006	SPRING, HANDLE LEVER	1	
• 38	90107-NX4-860	BOLT, TORX 8x38	4	
39	90114-MA5-671	BOLT, HANDLE LEVER	1	
• 40	90131-NX4-860	BOLT, FLANGE, 10x75	2	
41	90145-MS9-612	OIL BOLT, 10x22	1	
• 42	90145-NF4-650	BOLT, OIL BLEEDER	1	
43	90301-MG3-000	U-NUT 6mm	1	
• 44	90302-NX5-000	U-NUT, HEX., 6mm	1	
45	90473-147-000	WASHER, 6x16	1	
46	90601-ZE1-000	WASHER PLUG DRAWIN, 10MM	4	
47	90651-MA5-671	CIRCLIP	1	
• 48	90701-NX4-860	PIN, LOCK	1	
49	91212-422-006	O-RING, 14.8x2.4	1	
50	93600-04050-1G	SCREW, FLAT, 4x50	2	
51	95801-06025-00	BOLT., FLANGE, 6x25	2	
52	96300-06012-07	BOLT., FLANGE,DR, 6x12	1	
53	96300-06028-07	BOLT, FLANGE,DR, 6x28	1	

BLOCK No.
 F-4
 STEERING STEM •
 FENDER, FRONT •
 STEERING DAMPER

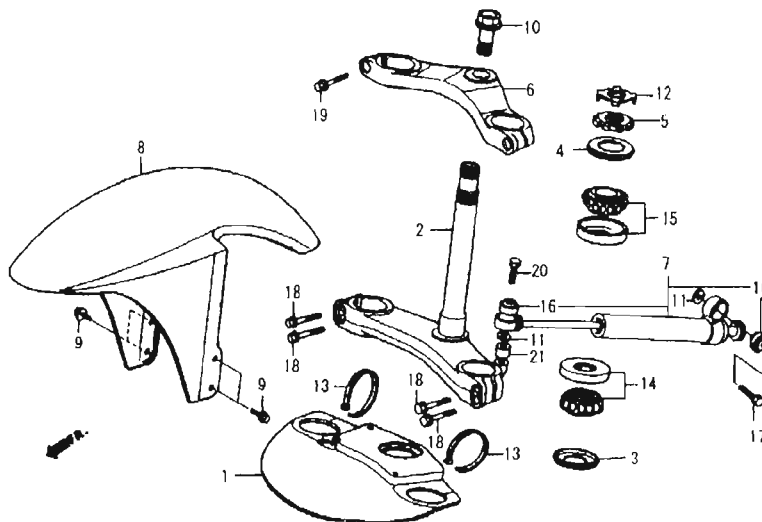

Ref. No.	Part No.	Description	Reqd. QTY	Retail Price
•	1	50820-NX4-000	COVER, STEERING UNDER	1
M	2	53219-10516-00	STEM COMP., STEERING, 32.5	1
	3	53214-KZ4-701	DUST-SEAL, STEERING HEAD	1
	4	53214-430-003	DUST-SEAL, STEERING HEAD	1
•	5	53229-NX4-000	THREAD, STEERING	1
M	6	53300-10516-00	BRIDGE, FORK TOP, 32.5	1
•	7	53700-NF4-900	DAMPER ASSY., STEERING	1
M	8	61100-10516-00	FENDER, FRONT	1
	9	90108-GK1-000	BOLT, FRANGE, SH, 6x12	4
•	10	90303-NX4-000	BOLT, STEERING STEM	1
	11	94102-08000	WASHER, 8MM	2
•	12	90506-NX4-000	STOPPER, STEERING THREAD	1
M	13	90650-35290-00	BAND, SELF LOCK 3.5x290	2
	14	91015-KZ4-701	BEARING, HEAD PIPE	1
	15	91015-425-831	BEARING, HEAD PIPE UP	1
	16	91060-NL0-003	BEARING, SPHERICAL, 8MM	2
M	17	90140-08025-41	BOLT, FLANGE CAP, 8x25	1
	18	95801-08028-00	BOLT, FLANGE, 8x28	4
	19	95801-08032-00	BOLT, FLANGE, 8x32	2
	20	90140-08040-41	BOLT, FLANGE CAP, 8x40	1
	21	0311-08161-1400	COLLAR	1

BLOCK No.
F-5
FRONT FORK

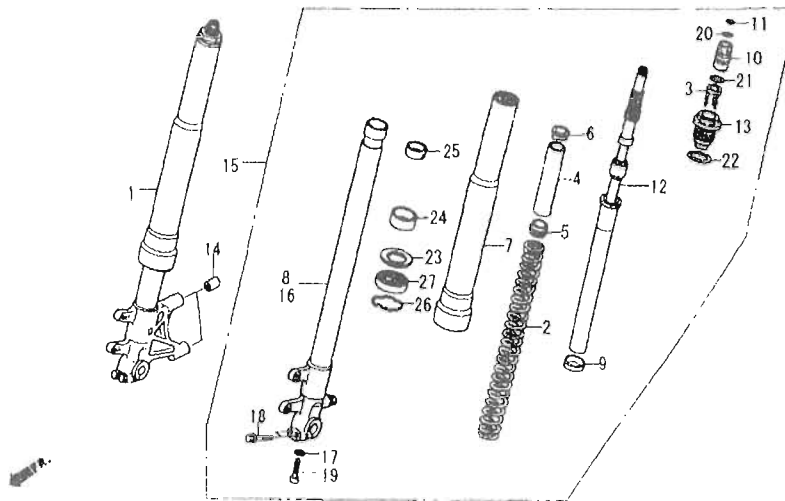

Ref. No.	Part No.	Description	Reqd. QTY	Retail Price
• 1	51400-NX4-862	FORK ASSY., R. FRONT	1	
• 2	51401-NX4-003	SPRING, FRONT FORK	2	K=0.6
•	51402-NX4-003	SPRING, FRONT FORK H	(2)	K=0.65
•	51403-NX4-003	SPRING, FRONT FORK S	(2)	K=0.5
• 3	51404-NF5-611	PLATE COMP., SPRING ADJUST	2	
• 4	51404-NX4-003	COLLAR, SPRING	2	
• 5	51405-NX4-003	PLATE, SPRING JOINT	2	
• 6	51406-NX4-003	STOPPER, SPRING SEAT	2	
• 7	51410-NX4-861	TUBE, OUTER	2	
• 8	51420-NX4-862	PIPE COMP., R. SLIDE	1	
• 9	51421-MW4-003	PLATE, CENTERING	2	
• 10	51422-NF5-611	ADJUSTER, SPRING	2	
• 11	51423-NF5-611	RING B, STOPPER	2	
• 12	51430-NX4-862	DAMPER COMP., FRONT	2	
• 13	51454-NX4-003	BOLT, FRONT FORK	2	
• 14	51497-MEL-000	SPACER, FR. FORK	2	
• 15	51500-NX4-862	FORK ASSY., L.. FRONT	1	
• 16	51520-NX4-861	PIPE COMP., L.. SLIDE	1	
• 17	52442-KA3-711	WASHER, SPECIAL, 10MM	2	
• 18	90107-KF0-000	BOLT, FLANGE, DR, 8x40	4	
• 19	90126-MR7-003	BOLT, SOCKET, 10x35	2	
• 20	91311-MR7-003	O-RING, 13.8x2.4	2	
• 21	91351-NF5-611	O-RING, 23.7x2.4	2	
• 22	91356-KA4-711	O-RING, 35.2x2.4	2	
• 23	51412-422-003	RING, BACK UP	2	
• 24	51414-NX4-702	BUSH, GUIDE	2	
• 25	51415-NX4-702	BUSH, SLIDE	2	
• 26	51447-KL4-951	RING, OIL SEAL STOP	2	
• 27	91255-NX4-771	SEAL, OIL 35x48x11	2	

BLOCK No.
F-6
FRONT WHEEL

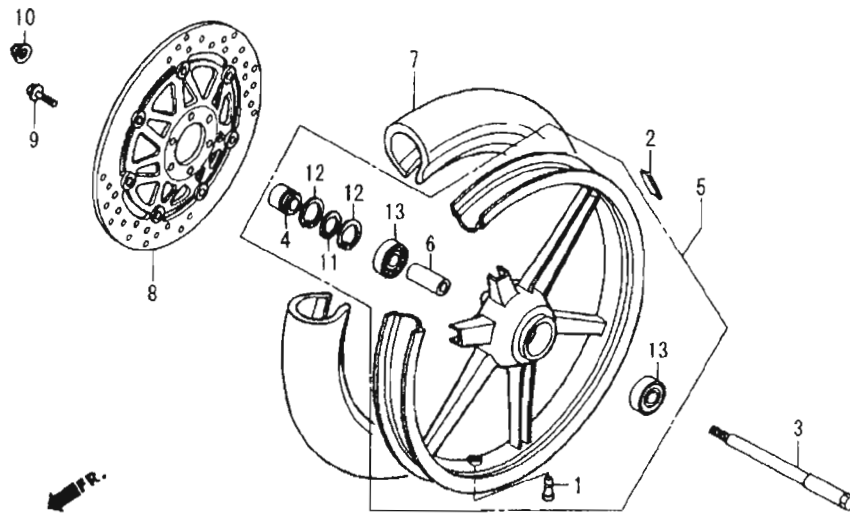

Ref. No.	Part No.	Description	Reqd. QTY	Retail Price
• 1	42704-NF5-710	VALVE, WHEEL	1	AL
	42753-ML7-004	VALVE, RIM(BS)	1	
• 2	42720-NC8-000	WEIGHT, BALANCER, 10G	N	
•	42721-NC8-000	WEIGHT, BALANCER, 20G	N	
• 3	44301-NX4-000	AXLE, FRONT WHEEL	1	
• 4	44303-NF4-000	COLLAR, FRONT WHEEL SIDE	1	
• 5	44600-NX4-306	WHEEL SET, FRONT(2.50x17)	1	BLACK
• 6	44620-NF4-000	COLLAR, FRONT WHEEL DISTANCE	1	
• 7		TIRE, FRONT (95/70-R17)(DL)	1	
• 8	45120-NX4-681	DISK COMP., R. FRONT BRAKE	1	SUS(STEEL)
• 9	90003-MB2-000	BOLT, FLANGE 6x20	6	
•	90113-ND5-761	BOLT, FLANGE 6x20	6	WIRE LOCK
• 10	90305-GE8-003	U-NUT, 14MM	1	
• 11	90651-NF4-000	CIRCLIP, EXTERNAL 26	1	
• 12	90652-NF4-000	CIRCLIP, INTERNAL 35	2	
• 13	96140-62020-10	BEARING, BALL RADIAL, 6202U	2	

BLOCK No.
 F-7
 REAR CALIPER
 REAR BRAKE MASTERCYLINDER

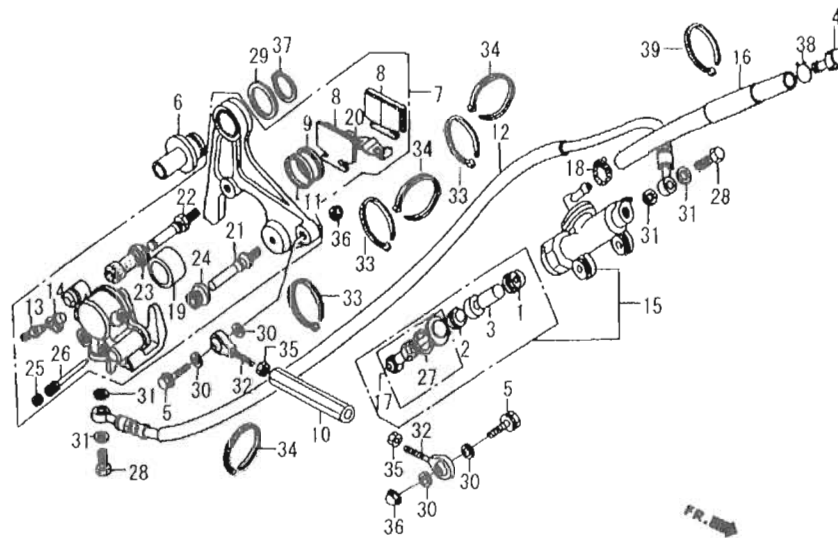

Ref. No.	Part No.	Description	Reqd. QTY	Retail Price
• 1	04601-ND5-760	CUP, PRIMARY	1	
• 2	04602-ND5-760	CUP, SECONDARY	1	
• 3	04603-NF4-770	PISTON, REAR	1	
4	17370-419-700	PLUG, BREATHER TUBE	1	
5	95801-08035-00	BOLT, FLANGE, 8x35	2	
• 6	42305-NX4-000	COLLAR, CALIPER BRACKET	1	
• 7	43100-NF5-612	CALIPER ASSY., REAR	1	
• 8	43105-NF5-612	PAD COMP	2	
• 9	43109-MA3-006	DUST SEAL	1	
M 10	43111-10512-10	ROD, REAR BRAKE TORQUE	1	
• 11	43209-MA3-006	SEAL, PISTON	1	
• 12	43310-NX4-003	HOSE, REAR BRAKE	1	
• 13	43352-568-003	SCREW, BLEEDER	1	
• 14	43353-461-771	CAP, BLEEDER	1	
• 15	43500-NF4-771	MASTER CYLINDER ASSY., REAR	1	
• 16	43503-NX4-000	V-TUBE, 9x13x275	1	
• 17	43504-NF4-770	ROD ASSY	1	
• 18	43541-ND5-750	CLAMP	1	
• 19	45107-GM9-711	PISTON	1	
• 20	45108-GM9-741	PAD SPRING	1	
• 21	45131-HA5-672	PIN, BOLT, A	1	
• 22	45131-166-016	PIN, BOLT	1	
• 23	45132-166-016	BUSH, PIN	1	
• 24	45133-MA3-006	BOOT, B	1	
• 25	45203-MG3-016	PLUG, PIN	2	

BLOCK No.
 F-7
 REAR CALIPER
 REAR BRAKE MASTERCYLINDER

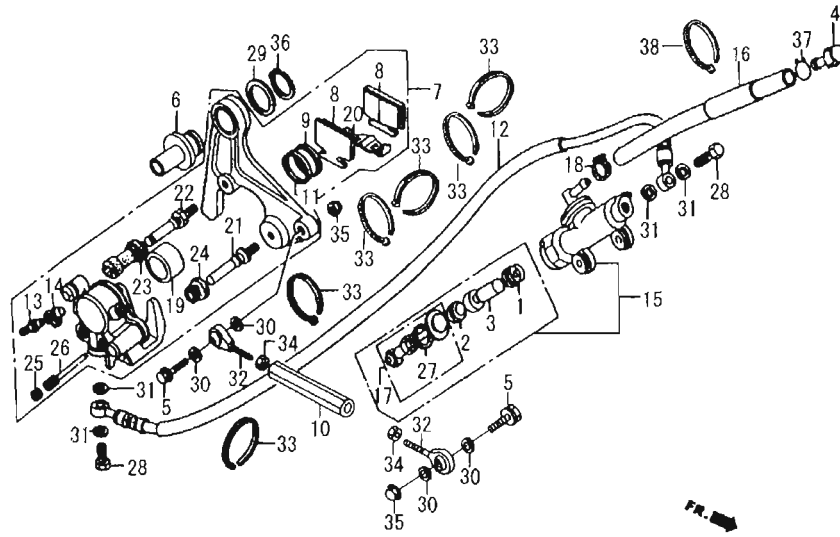

Ref. No.	Part No.	Description	Reqd. QTY	Retail Price
	26	45215-GE2-016	HANGER PIN	2
	27	46182-500-013	CIRCLIP, MASTER CYLINDER	1
	28	90145-MS9-612	OIL BOLT, 10x22	2
	29	90475-425-000	WASHER, THRUST, 30MM	1
	30	94102-08000	WASHER, PLAIN, 8MM	4
	31	90601-ZE1-000	WASHER, PLUG, DRAIN, 10MM	4
	32	91048-NX4-710	ROD END, 8MM	2
M	33	90650-35150-00	BAND, SELF LOCK 3.5x150 WT	6
	34	94002-08000-0S	NUT, HEX, 8MM	2
	35	94050-08000	NUT, FLANGE, 8MM	2
M	36	94510-30000	CIRCLIP, EXTERNAL, 30	1
	37	95002-02120	CLIP, B12 TUBE	1
	38	90650-25100-00	BAND, SELF LOCK 2.5x100 WT	1

BLOCK No.
F-8
REAR WHEEL

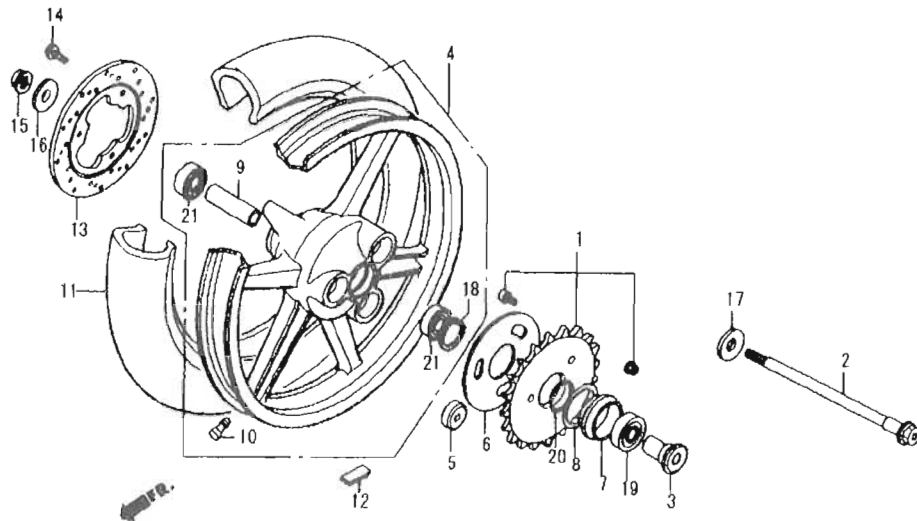

Ref. No.	Part No.	Description	Reqd. QTY	Retail Price	
• 1	41102-NX4-770	SPROCKET ASSY., FINAL DRIVEN 32T	(1)		
•	41103-NX4-770	SPROCKET ASSY., FINAL DRIVEN 33T	(1)		
•	41104-NX4-770	SPROCKET ASSY., FINAL DRIVEN 34T	(1)		
•	41105-NX4-770	SPROCKET ASSY., FINAL DRIVEN 35T	(1)		
•	41106-NX4-770	SPROCKET ASSY., FINAL DRIVEN 36T	1		
•	41107-NX4-770	SPROCKET ASSY., FINAL DRIVEN 37T	(1)		
•	41108-NX4-770	SPROCKET ASSY., FINAL DRIVEN 38T	(1)		
•	41109-NX4-770	SPROCKET ASSY., FINAL DRIVEN 39T	(1)		
•	41110-NX4-770	SPROCKET ASSY., FINAL DRIVEN 40T	(1)		
• 2	42301-NX4-000	AXLE, REAR WHEEL	1		
• 3	42304-NX4-000	COLLAR, REAR WHEEL SIDE	1		
• 4	42600-NX4-306	WHEEL SET, REAR(3.50x17)	1	BLACK	
• 5	42615-ND5-750	RUBBER, REAR WHEEL DAMPER	3		
• 6	42616-NF4-000	WASHER, SPROCKET	1		
• 7	42617-NF4-770	COLLER, SPROCKET	1		
• 8	42618-NF4-000	WASHER, COLLER SPROCKET 0.2	1		
•	42619-NF4-000	WASHER, COLLER SPROCKET 0.3	1		
• 9	42620-NX4-000	COLLER, REAR WHEEL DISTANCE	1		
• 10	42704-NF5-710	VALVE, WHEEL	1	AL	
	42753-ML7-003	VALVE, RIM(BS)	1		
11		TIRE REAR (115/70R17)(DL)	1		
• 12	42720-NC8-000	WHEIGHT, BALANCE, 10G	N		
•	42721-NC8-000	WHEIGHT, BALANCE, 20G	N		
• 13	43122-NF5-760	DISK, BRAKE	1	SUS(STEEL)	
	14	90105-KR3-000	BOLT, FRONT DISK, 8x24	3	
	15	90305-GE8-003	U-NUT, 14MM	1	

BLOCK No.
F-8
REAR WHEEL

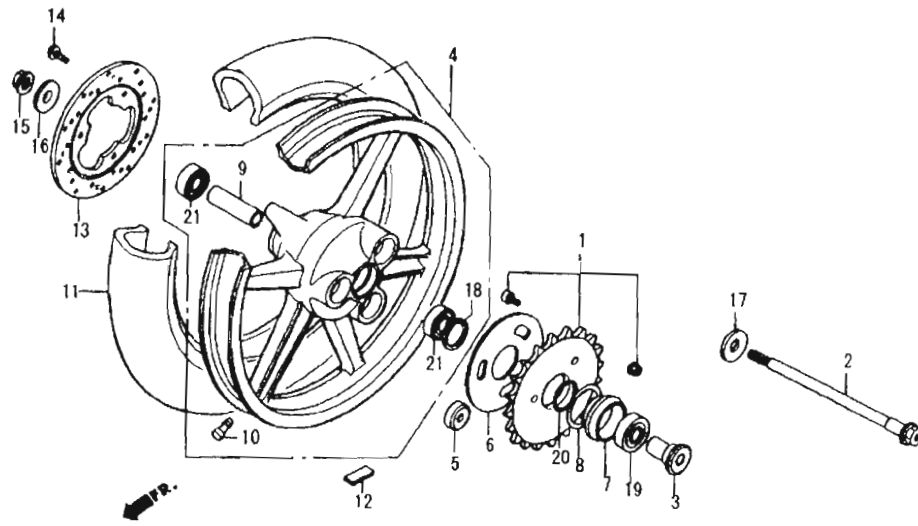

Ref. No.	Part No.	Description	Reqd. QTY	Retail Price
• 16	90411-NX4-000	WASHER, 14x32x1	1	
• 17	90456-NX4-000	WASHER, 18x32x1	1	
• 18	90652-NF4-000	CIRCLIP, INTERNAL 35	1	
• 19	91052-NF4-000	BEARING, BALL RADIAL, 6904UU	1	
20	91357-964-006	O-RING, 31	1	
21	96140-62020-10	BEARING, BALL RADIAL, 6202U	2	

BLOCK No.
F-9
FUEL TANK

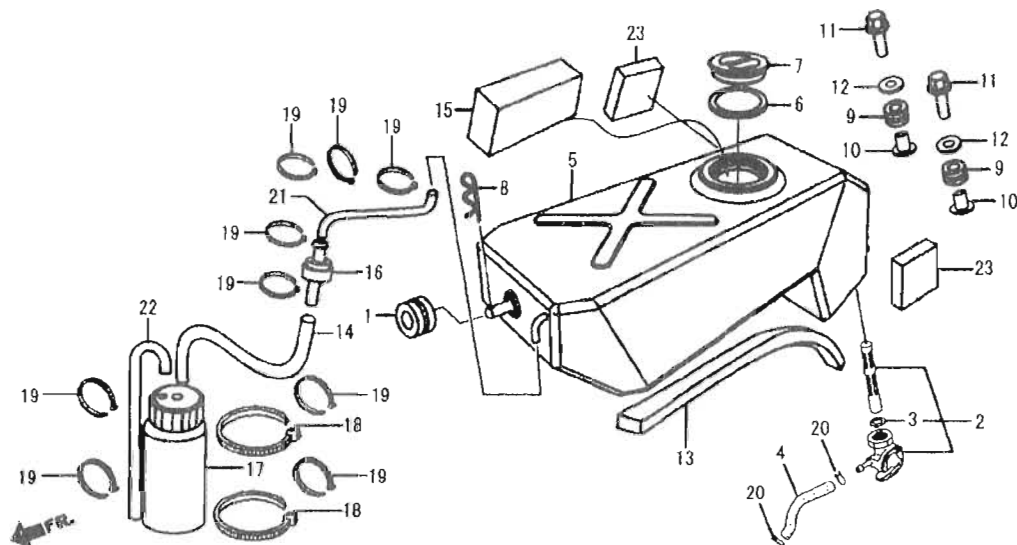

Ref. No.	Part No.	Description	Reqd. QTY	Retail Price
	1	18334-KA3-830	GROMMET, RUBBER	1
	2	16950-NF5-003	VALVE ASSY., FUEL	1
	3	16958-MA1-731	O-RING, 10x1.3	1
	4	17681-KRN-000	TUBE, FUEL	1
M	5	17520-10512-00	TANK COMP., FUEL	1
	6	17515-NX5-770	PACKING, FUEL CAP	1
M	7	17511-10172-00	CAP, FUEL TANK	1
	8	94252-10100	PIN, LOCK, 10	1
	9	19051-KA3-830	RUBBER, RADIATOR MOUNTING	2
	10	19052-MAC-680	COLLAR, RADIATOR MOUNTING	2
	11	96001-0602800	BOLT, FLANGE 6x28	2
	12	970-006-0201	WASHER 6MM	2
M	13	50283-10512-10	TAPE, INTERFERENCE, 30x10x430	2
M	14	17524-10512-00	VINYL-TUBE, 5x8x270	1
	15	17522-NF5-690	SPONGE, BUFFLE	4
	16	17625-NF4-003	VALVE COMP., CHECK	1
M	17	19602-NF4-810	TANK, CATCH 250	1
M	18	90650-35290-00	BAND, SELF LOCK 3.5x290 WT	2
M	19	90650-25100-00	BAND, SELF LOCK 2.5x100 WT	9
	20	95002-02120	CLIP, B12 TUBE	2
M	21	17522-10512-00	VINYL-TUBE, 5x8x400	1
M	22	17522-10512-00	VINYL-TUBE, 5x8x250	1
M	23	50283-10512-20	SPONGE, FUEL TANK, 10x80x80 GY	2

BLOCK No.
F-10
EXHAUST MUFFLER

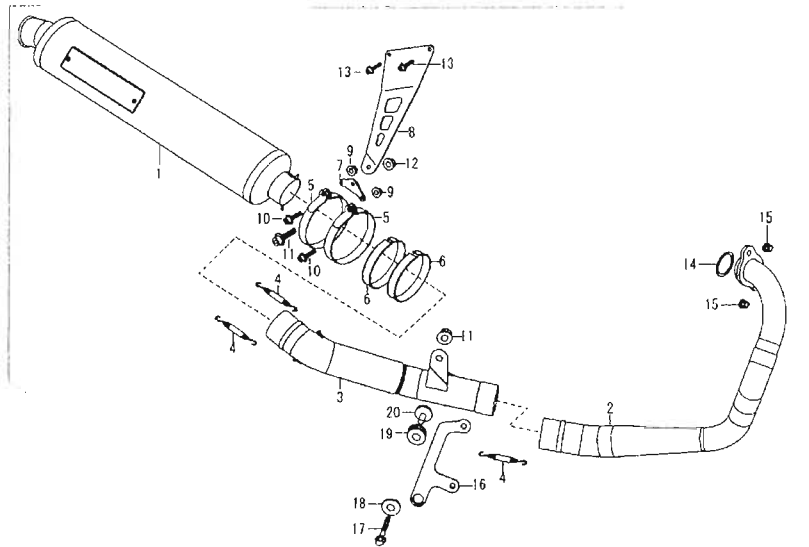

21

Ref. No.	Part No.	Description	Reqd. QTY	Retail Price
M 1	18910-J3512-00	SILENCER ASSY,	1	
M 2	18110-J3512-02	F.PIPE. COMP., EX.	1	
M 3	18210-J3512-02	T.PIPE. COMP., EX.	1	
M 4	0A02-08709-KK21	SPRING, LONG	3	
M 5	18931-L3168-00	BAND, SILENCER	2	
M 6	18932-LK168-00	RUBBER, BAND, SILENCER	2	
M 7	18940-L3158-10	SILENCER, BAND STAY,	1	
M 8	18950-J3512-00	STAY, SILENCER	1	
M 9	2100-060000010	NUT, FLANGE 6	2	
M 10	1261-060200210	BOLT, FLANGE CAP 6x20	2	
M 11	1261-080200410	BOLT, FLANGE CAP 8x20	1	
M 12	2100-080000010	NUT, FLANGE 8	2	
M 13	1261-060150210	BOLT, FLANGE CAP 6x15	2	
M 14	18291-MM5-860	GASKET, EX. PIPE	1	
M 15	94050-08000	NUT, FLANGE 8	2	
M 16	18240-J3512-00	SUBSTAY, TAILPIPE	1	
M 17	973010-08030	BOLT, FLANGE 8x30	1	
M 18	030A-08251-5100	WASHER, 8x25xt1.5	1	
M 19	0312-17250-DR00	GROMMET, RUBBER	1	
M 20	0312-11250-F010	GROMMET, COLLER	1	
M 21	01810-10512-00	MUFFLER, COMP.	1	

BLOCK No.
F-11
BRAKE PEDAL • STEP ARM

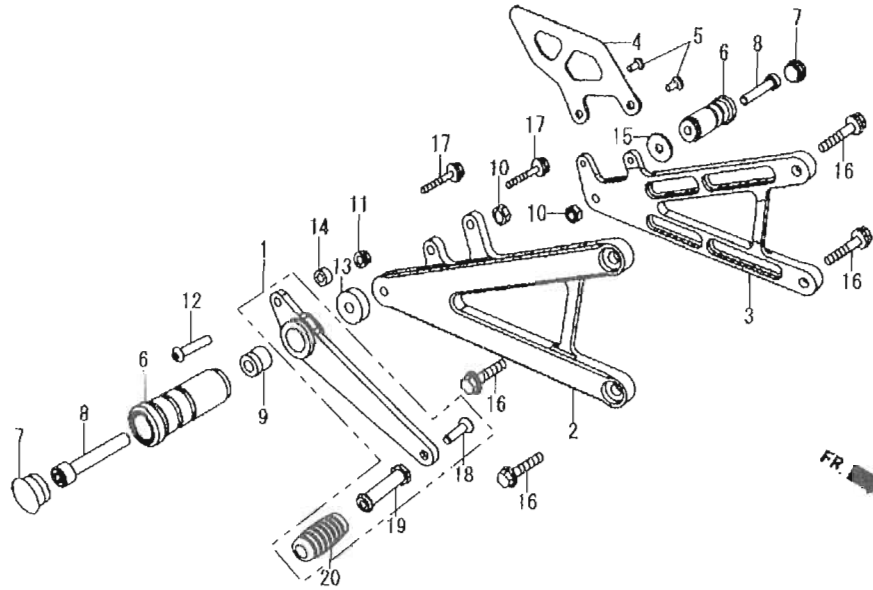

Ref. No.	Part No.	Description	Reqd. QTY	Retail Price	
M 1	46500-10516-00	PEDAL ASSY., BRAKE	1		
M 2	50600-10512-00	HOLDER STEP, R.	1		
M 3	50700-10512-00	HOLDER STEP, L.	1		
M 4	50707-10512-00	GUARD, L, STEP	1		
M 5	975010-06010	BOLT SOCKET, 6x10	2		
M 6	50660-20173-01	BAR, STEP	2		
M 7	50612-10516-00	END, STEP, BAR	2		
M 8	97001-08050	BOLT, CAP 8x50	2		
M 9	0311-08160-F100	COLLAR, PEADL	1		
M 10	973012-08000	U-NUT, 8mm	2		
	11	90301-473-003	NUT,LOCK,FLANGE,M6	1	
M 12	96650-06030-87	BOLT SOCKET, 6x30	1		
M 13	0311-08250-9400	COLLAR, 25x8.2x8.5	1		
M 14	0311-06120-6400	COLLAR, 12x6.2x6	1		
M 15	90504-MA6-000	WASHER, 8.5x26	1		
	16	95701-08020-00	BOLT, FLANGE 8x20	4	
	17	95701-06020-00	BOLT, FLANGE 6x20	2	
M 18	974010-06025	BOLT, TEPER CAP 6x25	1		
M 19	46515-10516-00	KNOB, PEDAL	1		
M 20	46501-10516-00	RUBBER, PEDAL KNOB	1		

BLOCK No.
F-12
CHANGE PEDAL ·
REAR SWING ARM

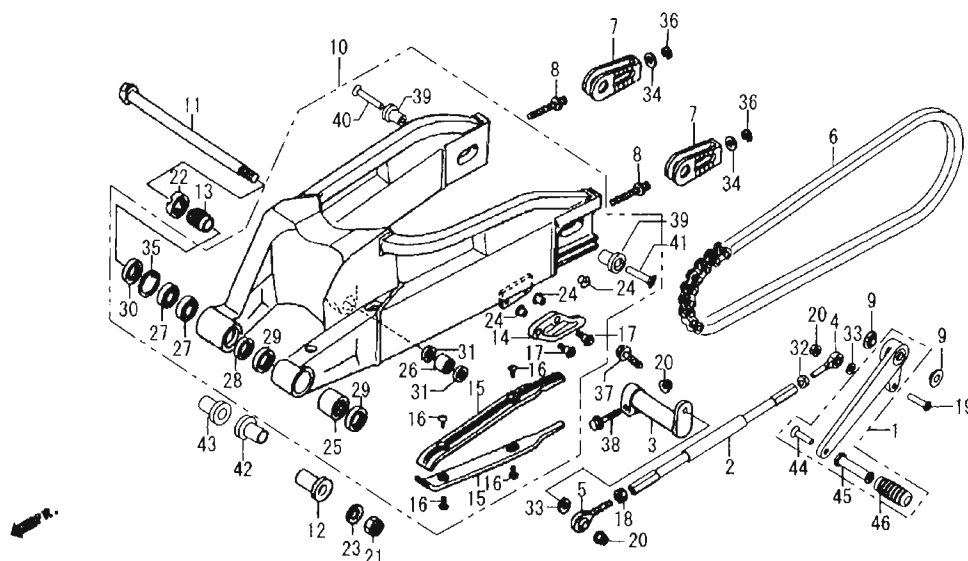

Ref. No.	Part No.	Description	Reqd. QTY	Retail Price
M 1	24720-10516-00	PEDAL ASSY., CHANGE	1	
M 2	24706-10512-01	ROD, CHANGE	1	
· 3	24710-NX4-000	ARM, GEAR CHANGE	1	
· 4	24711-NX4-710	ROD, END, 6MM A	1	
· 5	24712-NX4-710	ROD, END, 6MM B	1	
6		CHAIN, DRIVE (DID:415ER-120)	1	
· 7	40543-NX4-000	ADJUSTER, CHAIN	2	
· 8	40545-NX4-000	BOLT, CHAIN ADJUSTER	2	
M 9	24723-201D4-10	WASHER, PEDAL BEARING	2	
M 10	52200-10516-00	SWING ARM ASSY.	1	
· 11	52101-NX4-680	BOLT, SWING ARM PIVOT	1	
· 12	52106-NX4-000	COLLAR B, PIVOT	1	
· 13	52109-NX4-000	BOLT, ADJUST PIVOT	1	
14	52156-GAN-670	GUARD CHAIN	1	
· 15	52170-NX4-000	SLIDER, CHAIN	2	
16	90101-692-000	SCREW, TRUSS G.BO	4	
17	90110-GE0-710	BOLT, FLANGE, 6MM	2	
18	90201-KV3-700	NUT, TIE ROD B	1	
· 19	90211-NX4-771	BOLT SOCKET, 6x25	1	
20	90301-473-003	NUT, LOCK, FLANGE, M6	3	
21	90305-KZ4-891	U-NUT, 18MM	1	
· 22	90355-NX4-000	NUT, SWING ARM PIVOT	1	
23	90401-KZ4-890	WASHER, 18x32x2	1	
24	90522-028-000	WASHER, CHAIN CASE SETTING	3	
25	91071-MR7-003	BEARING NEEDLE	1	
26	91071-MY1-005	BEARING NEEDLE, 17x24x17	1	
27	91072-MR7-003	BEARING BALL RADIAL, 20x37x9	2	
M 28	91202-10512-00	DUST SEAL, 26x33x4	1	
29	91202-MR7-003	DUST SEAL, 28x37x4	2	

BLOCK No.
 F-12
 CHANGE PEDAL •
 REAR SWING ARM

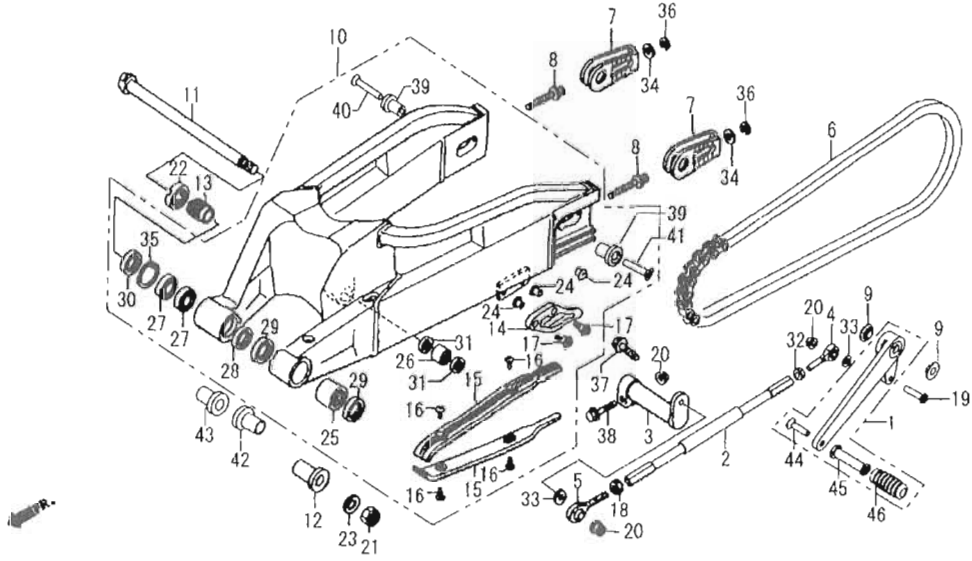

Ref. No.	Part No.	Description	Reqd. QTY	Retail Price
	30	91214-MR7-003	DUST SEAL, 26x37x5	1
	31	91262-KV3-831	DUST SEAL, 17x24x5	2
	32	94001-06200-0S	NUT, HEX, 6MM	1
	33	94101-06000	WASHER, PLAIN, 6MM	2
	34	94102-08000	WASHER, PLAIN, 8MM	2
	35	94520-37000	CIRCLIP, INTERNAL 37	1
	36	94540-07029	E-RING, 7	2
	37	96001-06022-00	BOLT, FLANGE, SH, 6x22	1
	38	96001-06028-00	BOLT, FLANGE, SH, 6x28	1
M	39	0312-06221-9400	COLLAR, STAND HOOK	2
M	40	974000-06040	BOLT, TEPER CAP 6x40	1
M	41	974000-06050	BOLT, TEPER CAP 6x50	1
M	42	52202-10512-01	COLLAR, DISTANCE., SWING ARM	1
M	43	52203-10512-01	COLLAR, DISTANCE., SWING ARM	1
M	44	974010-06025	BOLT, TEPER CAP 6x25	1
M	45	46515-10516-00	PEDAL KNOB	1
M	46	46501-10516-00	RUBBER, PEDAL KNOB	1

BLOCK No.
F-13
REAR CUSHION
CUSHION ROD

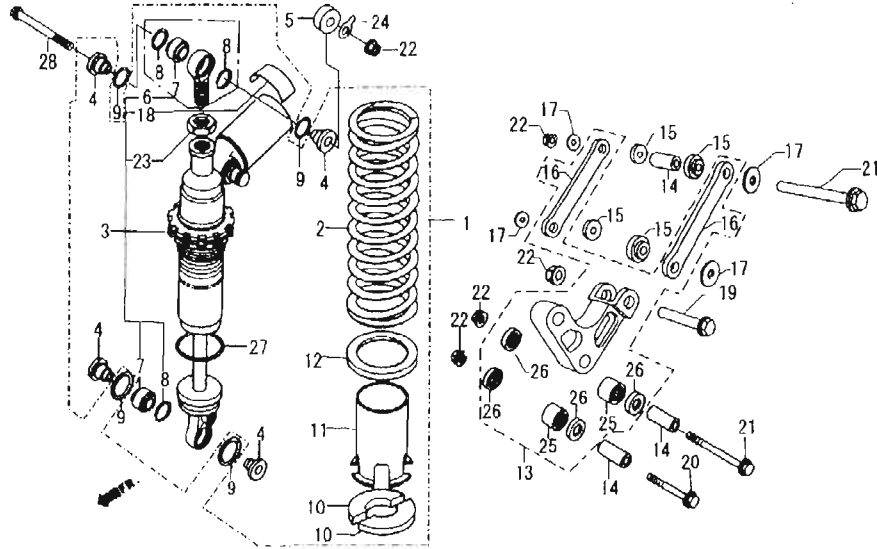

Ref. No.	Part No.	Description	Reqd. QTY	Retail Price
• 1	52400-NX4-812	CUSHION ASSY,REAR	1	
• 2	52401-NX4-003	SPRING,REAR CUSHION K=8.0	1 *YELLOW	
•	52402-NX4-003	SPRING,REAR CUSHION H K=8.5	(1) *RED	
•	52403-NX4-003	SPRING,REAR CUSHION S K=7.5	(1) *BLUE	
•	52404-NX4-701	SPRING,REAR CUSHION K=7.0	(1) *GREEN	
•	52405-NX4-701	SPRING,REAR CUSHION K=6.5	(1) *BLACK	
• 3	52410-NX4-812	DAMPER COMP,REAR	1	
• 4	52411-NX4-003	COLLAR,DAMPER UP	4	
M 5	52415-10512-00	COLLAR	1	
• 6	52420-NX4-003	JOINT COMP,UPPER	1	
• 7	52422-NF5-952	BEARRING,SPHERICAL	2	
• 8	52424-GC4-831	RING,STOPPER	3	
M 9	91309-10512-00	O-RING 15.0x3.5	4	
• 10	52455-NF4-781	STOPPER,SPRING SEAT	2	
• 11	52458-NX4-003	GUIDE,SPRING	1	
• 12	52459-NX4-003	SEAT,SPRING	1	
M 13	52460-10516-00	ROD ASSY,CUSHION M-03C	1	
• 14	52465-NX4-000	COLLAR,CUSHION ARM	3	
M 15	52476-10512-00	COLLAR,CUSHION ARM	4	
M 16	52475-10512-50	PLATE,CUSHION ARM M-03C	2	
M 17	030A-10302-0100	WASHER, 10x30xt2	4	
	18 87516-KS7-832	LABEL,REAR DAMPER	1	
	19 96400-1005000	BOLT,FLANGE 10x50	1	
	20 96400-1005500	BOLT,FLANGE 10x55	1	
	21 96400-1009000	BOLT,FLANGE 10x90	2	
	22 90304-GA6-003	NUT,AXLE	5	
• 23	90306-NF5-951	NUT,LOCK, 16MM	1	

*:MARKING COLLAR

BLOCK No.
 F-13
 REAR CUSHION
 CUSHION ROD

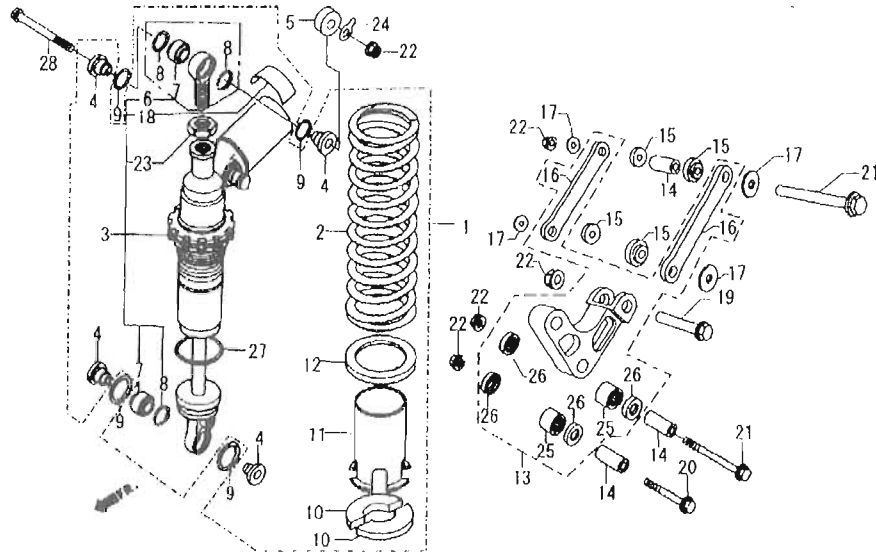

Ref. No.	Part No.	Description	Reqd. QTY	Retail Price
• 24	90510-NX4-000	SHIM,ENGINE MOUNT 0.2	N	
•	90511-NX4-000	SHIM,ENGINE MOUNT 0.6	N	
•	90512-NX4-000	SHIM,ENGINE MOUNT 1.0	N	
•	90513-NX4-000	SHIM,ENGINE MOUNT 1.5	N	
25	91071-MY1-005	BEARING, NEEDLE, 17x24x17	2	
26	91262-KV3-831	DUST SEAL, 17x24x5	4	
27	91356-KZ3-003	O-RING, 44.7x2.4	1	
28	90121-MFL-000	BOLT, FLANGE, 10x62	1	

BLOCK No.
F-14
BATTERY
WIRE HARNESS

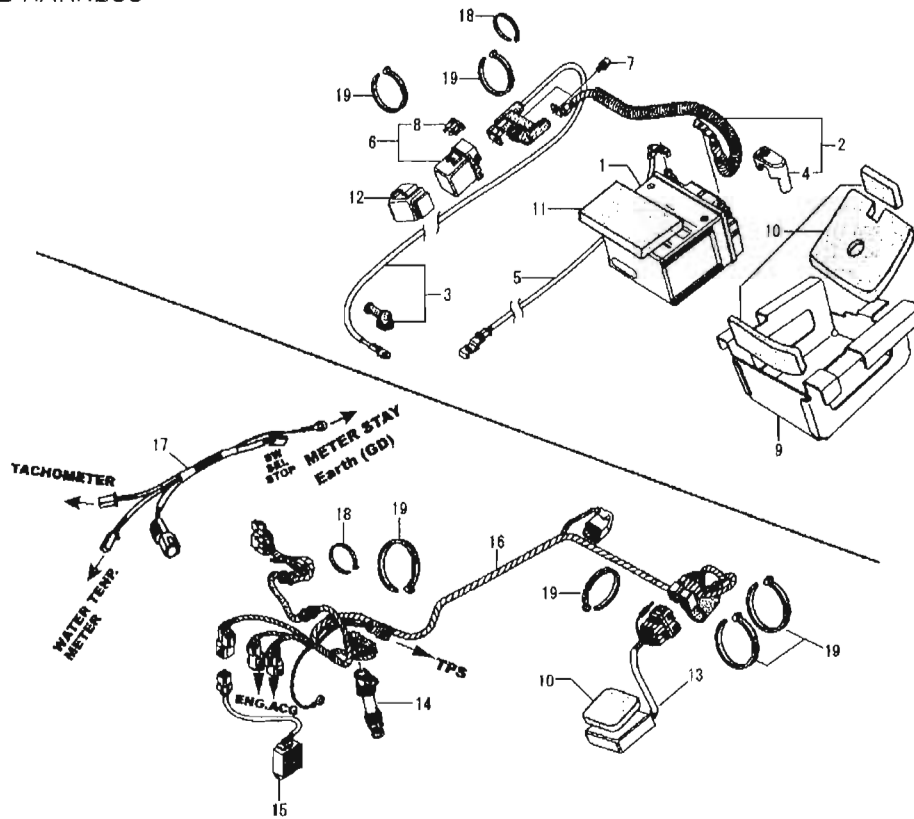

Ref. No.	Part No.	Description	Reqd. QTY	Retail Price
	1	31500-KY4-905 BATTERY(YTX5L-BS)(YUASA)	1	
M	2	32401-10512-A1 CABLE, STARTER MAGNETIC BATTERY	1	
	3	32410-KSC-670 CABLE, STATER MOTER	1	
M	4	32414-10512-00 COVER, BATTERY TERMINAL	1	
	5	32601-KSC-670 CABLE, BATTERY GROUND	1	
	6	35850-KK6-740 SWITCH ASSY., STARTER MAGNETIC	1	
	7	90111-MR5-000 BOLT, SOCKET (5X9)	2	
	8	98200-31500 FUSE, BLADE (15A)	1	
M	9	50320-10512-00 BOX, BATTERY	1	
M	10	18932-10512-00 RUBBER, CUSHION SHEET, REPAIR KIT	1	
M	11	18933-10512-00 RUBBER, CUSHION SHEET, BATTERY	1	
	12	35856-KBH-000 RUBBER, SHOCK	1	
	13	30410-KSC-A21 MODEULE, IGNITION CONTROL(CDI)	1	
	14	30700-KRN-670 CAP ASSY., NOISE SUPPRESSOR	1	
M	15	31600-KSC-671 RECTIFIER, REGULATOR	1	
M	16	32100-10516-00 WIRE HARNESS	1	
M	17	37253-10516-00 SUB HARNESS	1	
M	18	90650-25100-00 BAND, SELF LOCK 2.5x100 WT	3	
M	19	90650-35150-00 BAND, SELF LOCK 3.5x150 WT	6	

BLOCK No.
F-15
FRAME BODY • STAND •
BOX, CARBURETOR

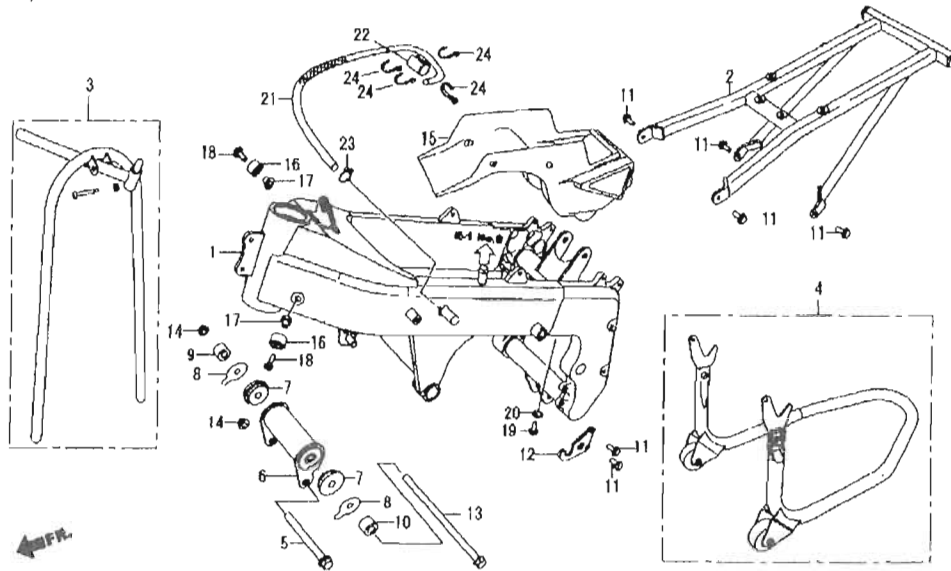

Ref. No.	Part No.	Description	Reqd. QTY
M 1	50100-10516-00	FRAME BODY COMP	1
M 2	50200-10512-00	RAIL COMP., SEAT	1
M 3	53500-10512-00	FRONT STAND	1
M 4	52500-10512-00	REAR STAND	1
	5	BOLT, FLANGE 10x110	1
M 6	50405-10512-00	STAY, RUBBER, ENGINE MOUNT	1
M 7	50408-10512-00	COLLAR, ENGINE MOUNT	2
M 8	90511-10512-00	SHIM, ENGINE MOUNT 0.4	N
M	90514-10512-00	SHIM, ENGINE MOUNT 1.0	N
M 9	50180-10512-01	COLLAR, ENGINE MOUNT R	1
M 10	50181-10512-01	COLLAR, ENGINE MOUNT L	1
	11	BOLT, FLANGE 6x14	6
M 12	24620-10512-00	PLATE, SHIFT GAIDE	1
	13	BOLT, FLANGE 10X205	1
	14	NUT, AXLE	2
M 15	64110-10516-00	BOX, CARBURETOR	1
	16	GUARD, WATER PIPE	1
	17	GROMMET COLLAR	2
	18	BOLT, SPECCIAL, 6x22	2
M 19	90108-GK1-000W	DRAIN BOLT 6x12	1
	20	WASHER, PLUG, DRAIN	1
M 21	17373-10516-00	VINYL-TUBE, BRETHER, FRAME 8x770	1
M 22	17374-10512-00	VINYL-TUBE, PROTECTION 12x70	1
	23	CLIP, TUBE B12	1
M 24	90650-25100-00	BAND, SELF LOCK 2.5x100 WT	4

BLOCK No.
F-16
RADIATOR

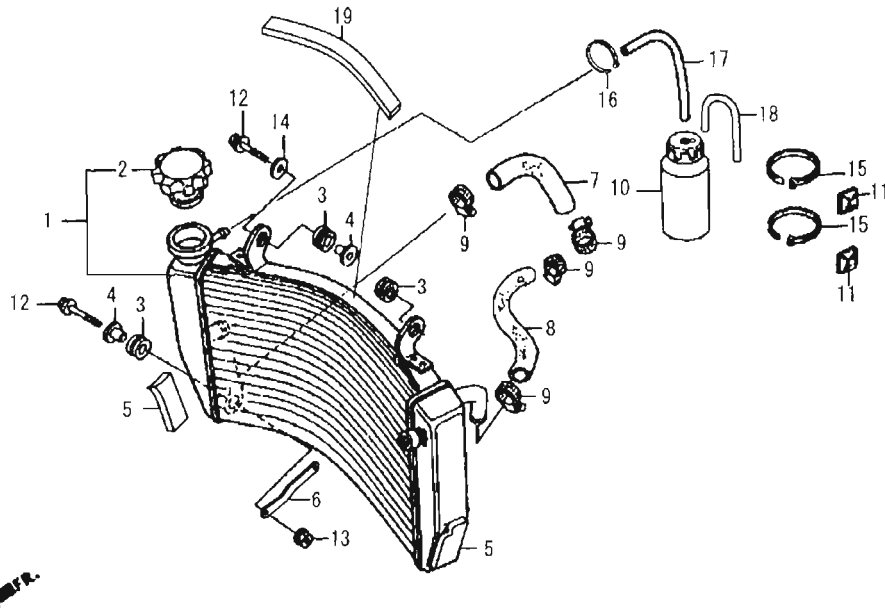

Ref. No.	Part No.	Description	Reqd. QTY	Retail Price
M 1	19010-10512-00	RADIATOR COMP.	1	
2	19045-MY3-671	CAP COMP., RADIATOR	1	
3	19051-KA3-830	RUBBER, RADIATOR MOUNT	3	
4	19052-MAC-680	COLLAR, RADIATOR MOUNT	2	
M 5	50283-10512-30	RUBBER, CUSHION SHEET 5x35x110 BK	2	
M 6	19110-10512-00	STAY, RADIATOR	1	
M 7	19062-10512-10	HOSE, WATER., LOWER	1	
M 8	19062-10512-20	HOSE, WATER., UPPER	1	
9	19506-KS6-700	CLAMP B, WATER HOSE	4	
- 10	19602-NF4-810	TANK, CATCH 250	1	
- 11	32114-NF4-780	BASE, TYLAP	2	
12	96001-06025-00	BOLT, FLANGE,SH, 6x25	2	
13	980010-06000	NUT,LOCK,FLANGE,M6	1	
14	90506-430-000	WASHER, FENDER MOUNT	1	
M 15	90650-35290-00	BAND, SELF LOCK 3.5x290 WT	2	
M 16	90650-25100-00	BAND, SELF LOCK 2.5x100 WT	1	
M 17	17525-10512-00	VINYL-TUBE, 5 x 8 x 320	1	
M 18	17523-10512-00	VINYL-TUBE, 5 x 8 x 250	1	
M 19	50283-10512-50	TAPE, INTERFERENCE 25x5x150	1	

BLOCK No.
F-17
COWLING

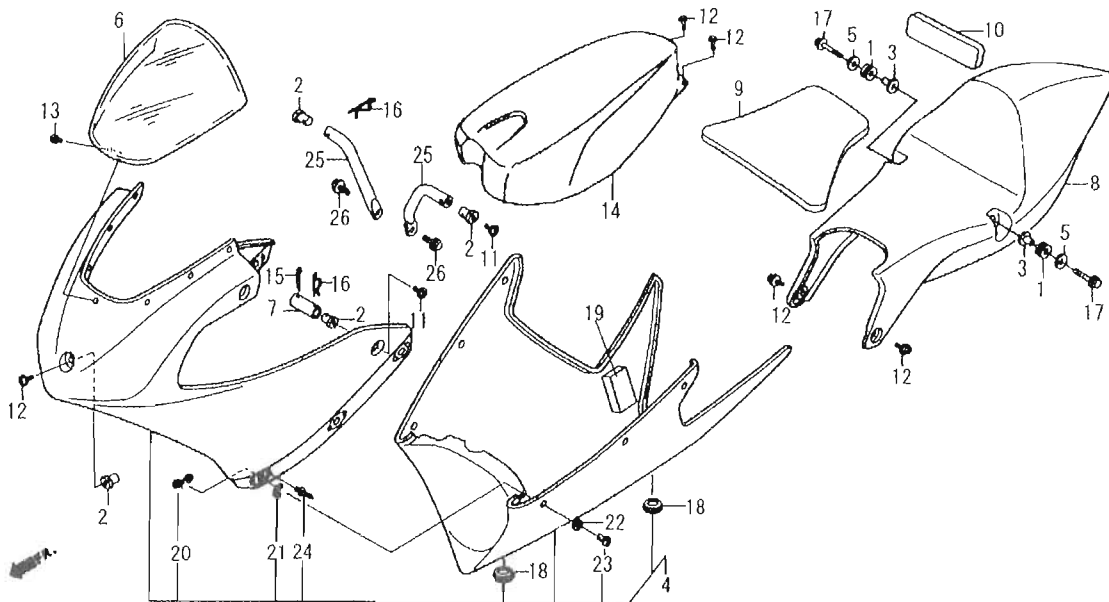

Ref. No.	Part No.	Description	Reqd. QTY	Retail Price
1	33712-KC5-003	GROMMET, TAILLIGHT MOUNT	2	
2	50803-NF4-610	NUT, COWL STAY	5	
3	61104-KA4-700	COLLAR, FENDER MOUNT	2	
M 4	64100-10516-10	COWLING, FRONT	1	
M 5	970-006-0201	WASHER, 6MM	2	
M 6	64200-10512-00	SCREEN	1	
7	64210-NX4-000	STAY, FRONT COWL SIDE	2	
M 8	77210-10512-10	COWL, SEAT	1	
9	77220-NX4-000	RUBBER, SEAT	1	
10	77221-NF5-760	RUBBER, SEAT BACK	1	
11	90106-NF4-770	BOLT, COWL SET, 6x13	5	
12	90108-GK1-000	BOLT, FLANGE,SH, 6x12	4	
13	90656-NX4-000	RIVET, 4x7	7	
M	90656-40080-00	RIVET, 4x8	N	
M 14	81240-10516-10	TANK, COVER	1	
15	94201-25300	PIN, SPLIT, 2.5x6.4	2	
16	94252-16100	PIN, LOCK, 16	4	
17	96001-06020-00	BOLT, FLANGE,SH, 6x20	2	
M 18	64491-02016-00	UNDER, COWL, PLUG	2	
M 19	50283-10512-40	CUSHION SHEET 10x30x40 GY	2	
20	90653-NC8-000	SPRING, FASTENER, 35	6	
21	94540-07029	E-RING7	6	
M 22	94102-08165-60	WASHER ,NYLON	6	
23	90655-NC8-000	STUD,FASTENER, 35	6	
24	91080-NC8-300	RIVET, 3.2x6.4	12	
M 25	64240-10516-00	STAY, FRONT COWL UPPER	2	
M 26	90004-GHB-620	BOLT, FLANGE, NSHF 6X14	2	

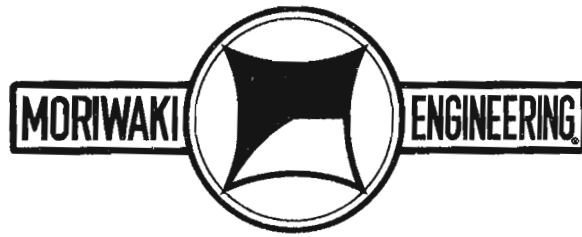

MORIWAKI ENGINEERING Co., Ltd.

6656-5 Sumiyoshi, Suzuka-City, Mie-Pref., JAPAN 513-0825

TEL: +81 (0)59-370-0090 FAX: +81 (0)59-370-0152

<http://www.moriwaki.co.jp/global/>