

DETONATION COUNTER

Installation Instructions:

1. Affix the detonation counter in location indicated by the illustration below using tie wraps or double-sided tape. The unit can also be attached next to the tachometer in the same fashion.
2. Attach the ground wire to the radiator stay.
3. Connect the included junction harness to the coupler from the water temp gauge for power.
4. With the recessed washer of the sensor facing upwards, torque the plug down to 2.5 kg/m .

NOTE: Be sure to use a needle type torque wrench to ensure the plug is tightened the proper amount every time. Changes in the amount of torque can result in different detonation counts as the unit uses a pressure sensor.

5. Connect the sensor coupler #1 to the left cylinder and #2 to the right cylinder.
6. Secure all harness wires with tie wraps.

Installation Diagram

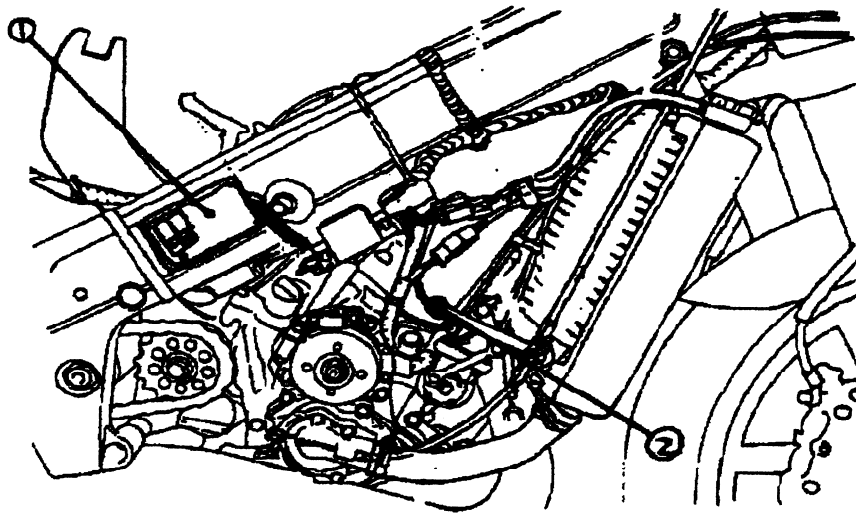

Power Consumption (12V 30mA)

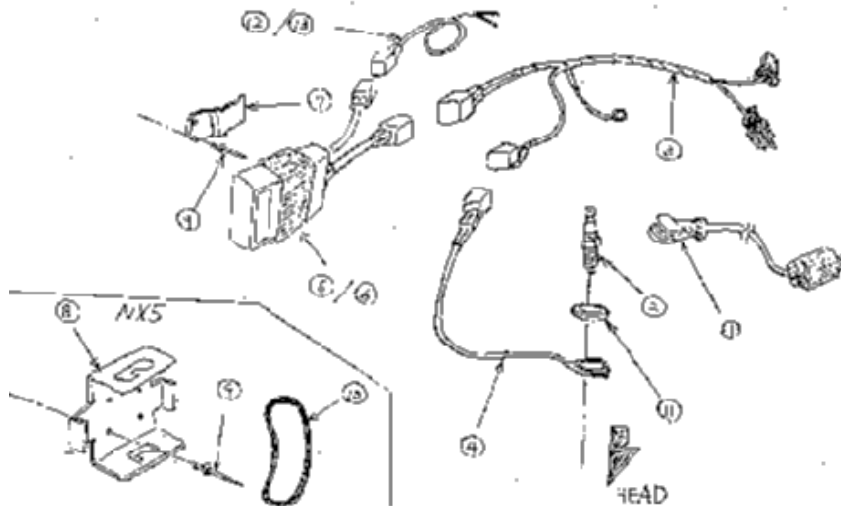

Directions

1. The counter unit has an internal battery which allows it to keep displaying 1 – 2 hours even after the engine is stopped.
2. The display will disappear after several hours of being inoperative, but will recharge once the engine is started again.
3. Be sure to reset the unit to zero with the reset button before riding.
4. Conduct setting based on a maximum of 5 times/ km with a target of 1-2 times/ km. For example, in the case of a 15 laps at a 4.2 km circuit:

Counter Reading	# 1	23
	# 2	33
# 1	$23 \div (4.2 \times 15) = 0.4 \text{ times/km}$	
# 2	$33 \div (4.2 \times 15) = 0.5 \text{ times/km}$	

NOTE: Detonation count differs with rider ability, riding style and circuit conditions. Be sure to check how the piston is burning in correlation with the detonation count while dialing the bike in.

Other General Notes and a couple on the Honda RS250:

First thing to make sure is that the copper washer is between the plug and the lead and that the lead is next the head or they will be no reading. Second thing is that if the plugs are NOT torqued to 25NM you can squeeze the leads and kill them.

A good way to test the wiring is, have the bike running...quickly switch the kill switch off and on. Every time you hit the kill switch you should increase the number on the counter by one.

Sometimes if you have a rich needle, clip position or power jet on a Honda you will get no dets. On a Honda RS250 a 40# Power jet, 1269,3466 needle on the middle clip should be in the ball park. It is important to remember when a Honda is detonating...it wont make good power. Get it starting to detonate then richen it one size on the main jet. Hondas are not like Yamahas...they like fuel and won't run on thin air!!!

Distributed by: **RISING SUN CYCLES, LLC**

Mailing: PO Box 122, South Station, Fall River, MA 02724-0122 USA

Parcel Shipping: 18 Pocasset Street, Fall River MA 02721 USA

860-916-3696

www.rscycles.com



Distributed by www.rscycles.com.